

INSTRUCTION MANUAL

22X PTZ III DOME CAMERA



Please read this manual thoroughly before use and keep it handy for future reference.

CAUTION

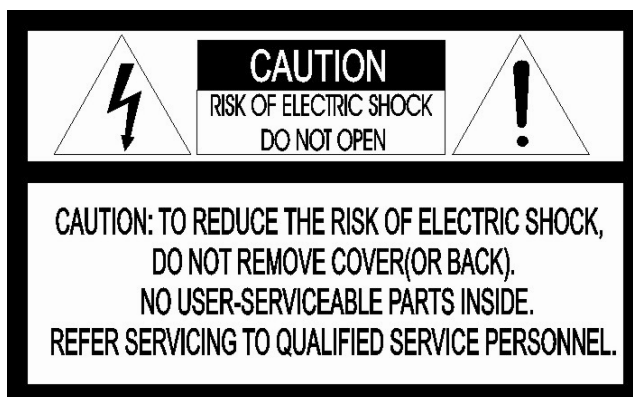

EXPLANATION OF GRAPHICAL SYMBOLS



The lightning flash with arrowhead symbol, within an equilateral triangle, is intended to alert the user to the presence of uninsulated “dangerous voltage” within the product’s enclosure that may be of sufficient magnitude to constitute a risk of electric shock to persons.



The exclamation point within an equilateral is intended to alert the user to the presence of important operating and maintenance (servicing) instructions in the literature accompanying the appliance.

FCC COMPLIANCE STATEMENT

FCC INFORMATION: THIS EQUIPMENT HAS BEEN TESTED AND FOUND TO COMPLY WITH THE LIMITS FOR A CLASS A DIGITAL DEVICE, PURSUANT TO PART 15 OF THE FCC RULES. THESE LIMITS ARE DESIGNED TO PROVIDE REASONABLE PROTECTION AGAINST HARMFUL INTERFERENCE WHEN THE EQUIPMENT IS OPERATED IN A COMMERCIAL ENVIRONMENT. THIS EQUIPMENT GENERATES, USES, AND CAN RADIATE RADIO FREQUENCY ENERGY AND IF NOT INSTALLED AND USED IN ACCORDANCE WITH THE INSTRUCTION MANUAL, MAY CAUSE HARMFUL INTERFERENCE TO RADIO COMMUNICATIONS. OPERATION OF THIS EQUIPMENT IN A RESIDENTIAL AREA IS LIKELY TO CAUSE HARMFUL INTERFERENCE IN WHICH CASE THE USER WILL BE REQUIRED TO CORRECT THE INTERFERENCE AT HIS OWN EXPENSE.

CAUTION: CHANGES OR MODIFICATIONS NOT EXPRESSLY APPROVED BY THE PARTY RESPONSIBLE FOR COMPLIANCE COULD VOID THE USER'S AUTHORITY TO OPERATE THE EQUIPMENT.

THIS CLASS A DIGITAL APPARATUS COMPLIES WITH CANADIAN ICES-003.

CET APPAREIL NUMÉRIQUE DE LA CLASSE A EST CONFORME À LA NORME NMB-003 DU CANADA.

CE COMPLIANCE STATEMENT

WARNING

THIS IS A CLASS A PRODUCT. IN A DOMESTIC ENVIRONMENT THIS PRODUCT MAY CAUSE RADIO INTERFERENCE IN WHICH CASE THE USER MAY BE REQUIRED TO TAKE ADEQUATE MEASURES.

IMPORTANT SAFETY INSTRUCTIONS

1. Read these instructions.
2. Keep these instructions.
3. Heed all warnings.
4. Follow all instructions.
5. Clean only with dry cloth.
6. Do not block any ventilation openings. Install in accordance with the manufacturer's instructions.
7. Do not install near any heat sources such as radiators, heat registers, stoves, or other apparatus (including amplifiers) that produce heat.
8. Do not defeat the safety purpose of the polarized or grounding-type plug. A polarized plug has two blades with one wider than the other. A grounding type plug has two blades and a third grounding prong. The wide blade or the third prong are provided for your safety. If the provided plug does not fit into your outlet, consult an electrician for replacement of the obsolete outlet.
9. Protect the power cord from being walked on or pinched particularly at plugs, convenience receptacles, and the point where they exit from the apparatus.
10. Only use attachments/accessories specified by the manufacturer.
11. Use only with the cart, stand, tripod, bracket, or table specified by the manufacturer, or sold with the apparatus. When a cart is used, use caution when moving the cart/apparatus combination to avoid injury from tip-over.
12. Unplug this apparatus during lightning storms or when unused for long periods of time.
13. Refer all servicing to qualified service personnel. Servicing is required when the apparatus has been damaged in any way, such as power-supply cord or plug is damaged, liquid has been moisture, does not operate normally, or has been dropped.
14. **CAUTION – THESE SERVICING INSTRUCTIONS ARE FOR USE BY QUALIFIED SERVICE PERSONNEL ONLY. TO REDUCE THE RISK OF ELECTRIC SHOCK DO NOT PERFORM ANY SERVICING OTHER THAN THAT CONTAINED IN THE OPERATING INSTRUCTIONS UNLESS YOU QRE QUALIFIED TO DO SO.**
15. **Use Certified/Listed Class 2 power source only.**



Table of Contents

Chapter 1 — Introduction	1
1.1 Features	1
Chapter 2 — Installation and Configuration	2
2.1 Package Contents.....	2
2.2 Installation	3
2.3 Basic Configuration of Dome Camera System	4
2.4 Setting Dome Camera Termination	5
2.5 Setting Dome Camera Address (ID).....	5
2.6 Setting Dome Camera Protocol and Video	12
2.7 Connections.....	12
2.8 Getting Started	13
Chapter 3 — Program and Operation	14
3.1 Dome Camera Selection	14
3.2 Accessing the On-Screen Menu Utility	14
3.3 How to control the On-Screen Menu Utility	15
3.4 Auto Scan (Shortcut: SCAN)	15
3.5 Preset (Shortcut: PRST)	17
3.6 Shortcut of Preset Program	19
3.7 Tour (Shortcut: TOUR)	19
3.8 Pattern (Shortcut: PTRN).....	21
3.9 Alarm.....	22
3.10 Area Title.....	22
3.11 Privacy Zone	23
3.12 Camera Menu.....	24
3.13 Dome Setup	27
3.14 Function Run	33
3.15 Factory Setup	34
Appendix A — Specifications	35
Appendix B — Troubleshooting	36
Appendix C — Glossary	37
Appendix D — Short Cut Key	40
Appendix E — Wall Mount	41
Appendix F — Ceiling Mount	42

Chapter 1 — Introduction

1.1 Features

The dome camera and the keyboard controller make up the building blocks for any surveillance/security system. Using multiple keyboard controllers and multiple dome cameras, no place is too large for monitoring. Extensible and flexible architecture facilitates remote control functions for a variety of external switching devices such as multiplexers and DVRs.

- Built-in optical power zoom camera with True Night Shot function.
- 120 Preset positions with the individual Camera AE setup.
- 4 Tours consist of Presets, Patterns, Auto Scans and other Tours can be programmed with over 150 functions and Preset locations. While moving, each Preset scan can be watched in smooth **Vector Scan** mode.
- 4 Auto Scans with the normal, the vector, and the **random** mode and the Endless Auto-Pan with 13 speed steps.
- 4 Patterns (up to 200 second) and 4 Privacy Zones.
- 8 Area Titles.
- 1 Alarm input / 1 Alarm output (TTL ON/OFF)
- Variable speed from 0.1°/sec to 380°/sec.
Three Variable speed (SLOW, NORMAL, TURBO).
Turbo speed is 380°/sec with Ctrl key pressed.
- Pan / Tilt speed is inversely proportional to the zoom ratio with the option.
- Maximum speed is 380°/sec when Preset command.
- Auto Calibration from 0.1° to 6° (Tilt range is 0° to 180°).
- Programmable user preferences (alarm, preset, title, etc.).
- 180° Digital Flip.
- Up to 255 selectable camera addresses.
- Multi-language Menu Display, Password Confirmation.
- Function Run menu using DVR without function key (Pattern, Scan,..)
- Built-in RS-485 receiver driver.
- AC 24V or DC 12V for Dome.
- AC 24V for Heater & Fan.
- Use Certified/Listed Class 2 power source only.

Chapter 2 — Installation and Configuration

2.1 Package Contents

The dome camera is design to a compact, small size, hard dome camera housing. The housing is constructed of aluminum, steel and plastic. The housing is designed to be mounted both wall and ceiling type.

The housing meets the Protection Classification IP66 standards for dust and moisture resistance.

- * **Dome Camera**1
- * **Instruction Manual (This Document)**1
- * **Accessory kit & connector**.....1
 - 1) Torx wrench(1)
 - 2) 2Pin Terminal Block(1)
 - 3) 3Pin Terminal Block(2)
 - 4) 4Pin Terminal Block(1)

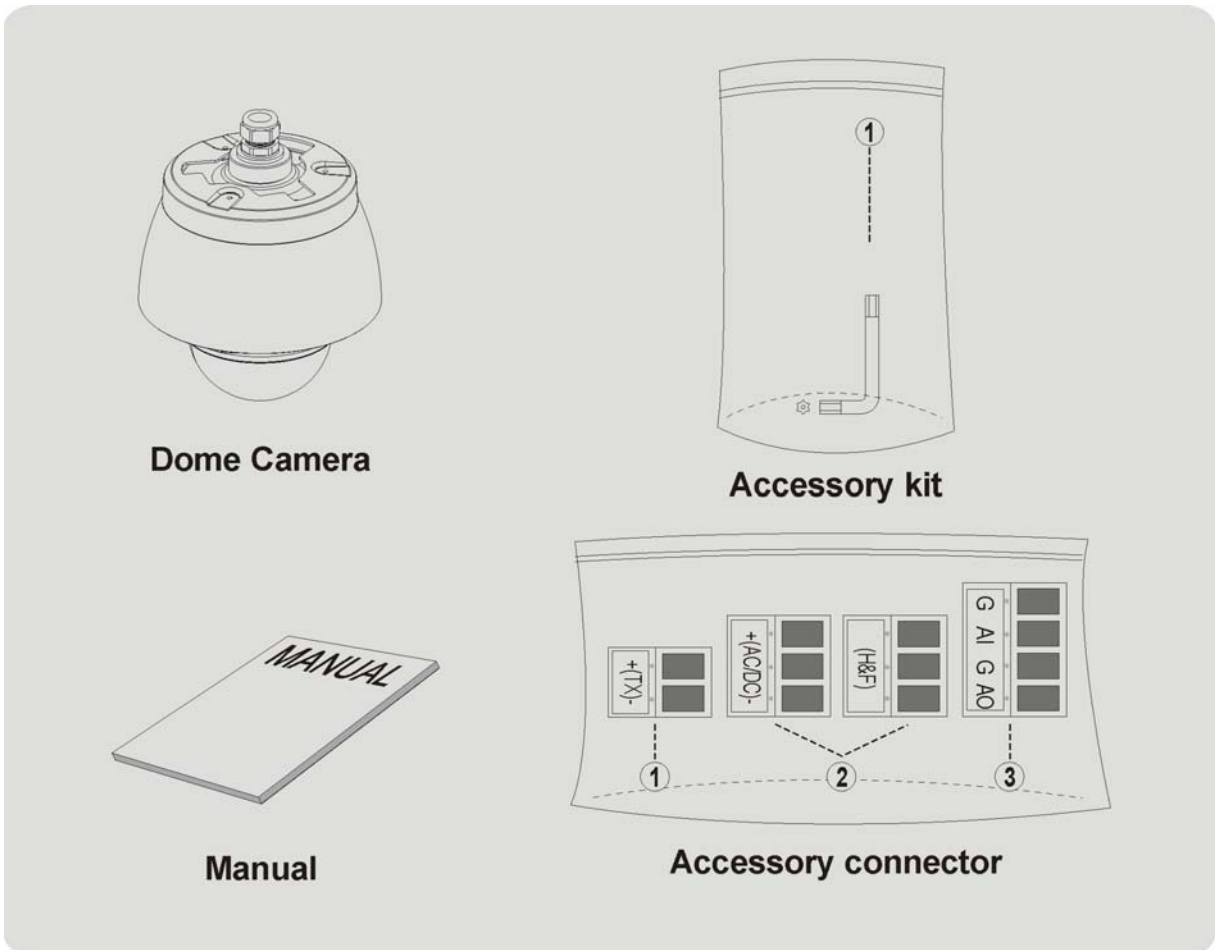

2.2 Installation

You need one optional mount kit of the wall mount and the ceiling mount to install.

The wall or ceiling mount must be attached to a structural object such as hard wood, concrete that will support the weight of the mount and dome camera.

The use of a solid backboard is recommended when attaching to gypsum walls.

1. Remove the Protection pad and the tape from attached the dome camera.
2. Attach the mounting base to wall using the supplied M8 tapping screw and plastic bushing. (Ceiling using the supplied M6 tapping screw and bushing)
3. Wind the both thread of the pipe end with Teflon tape about 20times for sealing. Then use a silicone rubber sealant to seal the area where the wall (ceiling) mount and the pipe meet.
4. Place a bead of silicone sealant around the wall and ceiling mount mounting flange, press it to the surface and line up the flange hole with drilled holes.
5. Refer to the Appendix E and F.

CAUTION: A silicone rubber sealant must be applied to seal the housing to secure waterproofing.

CAUTION: When installing, a bracket must be applied.

2.3 Basic Configuration of Dome Camera System

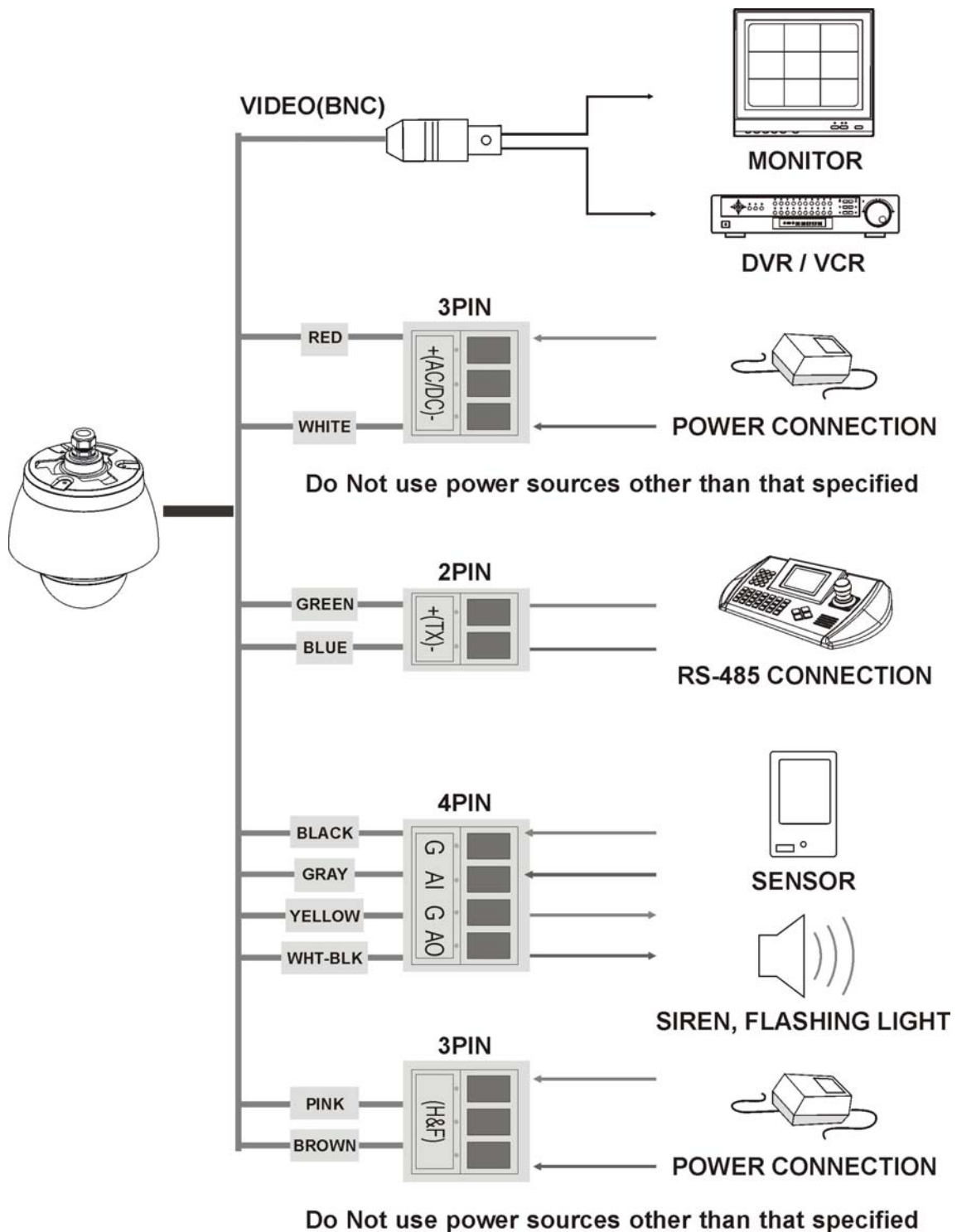

Figure 1 – Basic Installation Diagram

The dome camera must be installed by qualified service personnel in accordance with all local and federal electrical and building codes.

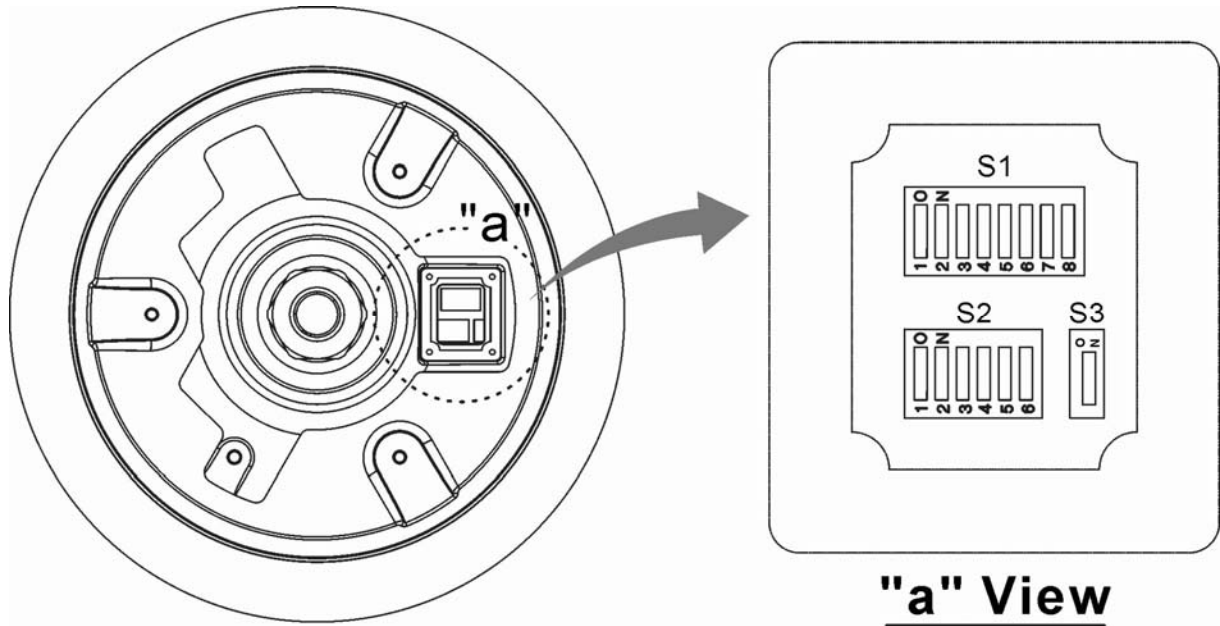

Figure 2 – Layout of DIP Switches

NOTE: Open the switch cover (position “a”) and change the setting of DIP switches. The cover should be closed after setting DIP switches.

2.4 Setting Dome Camera Termination

The device which is connected at end of line, whether it is a dome camera or keyboard controller, must have the cable for communication terminated by setting the appropriate DIP switch. Without proper termination, there is potential for control signal errors. Total length of the cable for communication should not exceed 4000ft (1.2km).



S3

S3	D1
Terminated	ON
Not terminated	OFF

Figure 3 – Setting Dome Camera Termination

2.5 Setting Dome Camera Address (ID)

To prevent damage, each dome camera must have a unique address (ID).

When installing multiple dome cameras using a multiplexer, it is suggested that the dome camera address match the multiplexer port number.

The factory default setting is 1.

Refer to Figure 4.1 ~ 4.6 for setting the dome camera address (ID).

Example: Port 1 = Dome 1, Port 2 = Dome 2 ... Port 16 = Dome 16. If more than 16 dome cameras are installed using two or more multiplexers, ID of the dome camera should be ID of MUX x No. of camera IN. (e.g. multiplexer ID= n, Camera IN= m then ID of Dome =16x(n-1)+m)

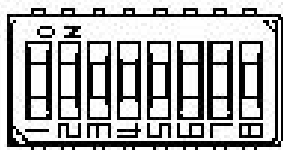

S1

DOME ID	D1 (1)	D2 (2)	D3 (4)	D4 (8)	D5 (16)	D6 (32)	D7 (64)	D8 (128)
1	ON	OFF	OFF	OFF	OFF	OFF	OFF	OFF
2	OFF	ON	OFF	OFF	OFF	OFF	OFF	OFF
3	ON	ON	OFF	OFF	OFF	OFF	OFF	OFF
4	OFF	OFF	ON	OFF	OFF	OFF	OFF	OFF
5	ON	OFF	ON	OFF	OFF	OFF	OFF	OFF
6	OFF	ON	ON	OFF	OFF	OFF	OFF	OFF
7	ON	ON	ON	OFF	OFF	OFF	OFF	OFF
8	OFF	OFF	OFF	ON	OFF	OFF	OFF	OFF
9	ON	OFF	OFF	ON	OFF	OFF	OFF	OFF
10	OFF	ON	OFF	ON	OFF	OFF	OFF	OFF
11	ON	ON	OFF	ON	OFF	OFF	OFF	OFF
12	OFF	OFF	ON	ON	OFF	OFF	OFF	OFF
13	ON	OFF	ON	ON	OFF	OFF	OFF	OFF
14	OFF	ON	ON	ON	OFF	OFF	OFF	OFF
15	ON	ON	ON	ON	OFF	OFF	OFF	OFF
16	OFF	OFF	OFF	OFF	ON	OFF	OFF	OFF
17	ON	OFF	OFF	OFF	ON	OFF	OFF	OFF
18	OFF	ON	OFF	OFF	ON	OFF	OFF	OFF
19	ON	ON	OFF	OFF	ON	OFF	OFF	OFF
20	OFF	OFF	ON	OFF	ON	OFF	OFF	OFF
21	ON	OFF	ON	OFF	ON	OFF	OFF	OFF
22	OFF	ON	ON	OFF	ON	OFF	OFF	OFF
23	ON	ON	ON	OFF	ON	OFF	OFF	OFF
24	OFF	OFF	OFF	ON	ON	OFF	OFF	OFF
25	ON	OFF	OFF	ON	ON	OFF	OFF	OFF
26	OFF	ON	OFF	ON	ON	OFF	OFF	OFF
27	ON	ON	OFF	ON	ON	OFF	OFF	OFF
28	OFF	OFF	ON	ON	ON	OFF	OFF	OFF
29	ON	OFF	ON	ON	ON	OFF	OFF	OFF
30	OFF	ON	ON	ON	ON	OFF	OFF	OFF
31	ON	ON	ON	ON	ON	OFF	OFF	OFF
32	OFF	OFF	OFF	OFF	OFF	ON	OFF	OFF
33	ON	OFF	OFF	OFF	OFF	ON	OFF	OFF
34	OFF	ON	OFF	OFF	OFF	ON	OFF	OFF
35	ON	ON	OFF	OFF	OFF	ON	OFF	OFF

Figure 4.1 – Setting Dome Camera Address (ID)

DOME ID	D1 (1)	D2 (2)	D3 (4)	D4 (8)	D5 (16)	D6 (32)	D7 (64)	D8 (128)
36	OFF	OFF	ON	OFF	OFF	ON	OFF	OFF
37	ON	OFF	ON	OFF	OFF	ON	OFF	OFF
38	OFF	ON	ON	OFF	OFF	ON	OFF	OFF
39	ON	ON	ON	OFF	OFF	ON	OFF	OFF
40	OFF	OFF	OFF	ON	OFF	ON	OFF	OFF
41	ON	OFF	OFF	ON	OFF	ON	OFF	OFF
42	OFF	ON	OFF	ON	OFF	ON	OFF	OFF
43	ON	ON	OFF	ON	OFF	ON	OFF	OFF
44	OFF	OFF	ON	ON	OFF	ON	OFF	OFF
45	ON	OFF	ON	ON	OFF	ON	OFF	OFF
46	OFF	ON	ON	ON	OFF	ON	OFF	OFF
47	ON	ON	ON	ON	OFF	ON	OFF	OFF
48	OFF	OFF	OFF	OFF	ON	ON	OFF	OFF
49	ON	OFF	OFF	OFF	ON	ON	OFF	OFF
50	OFF	ON	OFF	OFF	ON	ON	OFF	OFF
51	ON	ON	OFF	OFF	ON	ON	OFF	OFF
52	OFF	OFF	ON	OFF	ON	ON	OFF	OFF
53	ON	OFF	ON	OFF	ON	ON	OFF	OFF
54	OFF	ON	ON	OFF	ON	ON	OFF	OFF
55	ON	ON	ON	OFF	ON	ON	OFF	OFF
56	OFF	OFF	OFF	ON	ON	ON	OFF	OFF
57	ON	OFF	OFF	ON	ON	ON	OFF	OFF
58	OFF	ON	OFF	ON	ON	ON	OFF	OFF
59	ON	ON	OFF	ON	ON	ON	OFF	OFF
60	OFF	OFF	ON	ON	ON	ON	OFF	OFF
61	ON	OFF	ON	ON	ON	ON	OFF	OFF
62	OFF	ON	ON	ON	ON	ON	OFF	OFF
63	ON	ON	ON	ON	ON	ON	OFF	OFF
64	OFF	OFF	OFF	OFF	OFF	OFF	ON	OFF
65	ON	OFF	OFF	OFF	OFF	OFF	ON	OFF
66	OFF	ON	OFF	OFF	OFF	OFF	ON	OFF
67	ON	ON	OFF	OFF	OFF	OFF	ON	OFF
68	OFF	OFF	ON	OFF	OFF	OFF	ON	OFF
69	ON	OFF	ON	OFF	OFF	OFF	ON	OFF
70	OFF	ON	ON	OFF	OFF	OFF	ON	OFF
71	ON	ON	ON	OFF	OFF	OFF	ON	OFF
72	OFF	OFF	OFF	ON	OFF	OFF	ON	OFF
73	ON	OFF	OFF	ON	OFF	OFF	ON	OFF
74	OFF	ON	OFF	ON	OFF	OFF	ON	OFF
75	ON	ON	OFF	ON	OFF	OFF	ON	OFF
76	OFF	OFF	ON	ON	OFF	OFF	ON	OFF
77	ON	OFF	ON	ON	OFF	OFF	ON	OFF
78	OFF	ON	ON	ON	OFF	OFF	ON	OFF
79	ON	ON	ON	ON	OFF	OFF	ON	OFF
80	OFF	OFF	OFF	OFF	ON	OFF	ON	OFF

Figure 4.2 – Setting Dome Camera Address (ID)

DOME ID	D1 (1)	D2 (2)	D3 (4)	D4 (8)	D5 (16)	D6 (32)	D7 (64)	D8 (128)
81	ON	OFF	OFF	OFF	ON	OFF	ON	OFF
82	OFF	ON	OFF	OFF	ON	OFF	ON	OFF
83	ON	ON	OFF	OFF	ON	OFF	ON	OFF
84	OFF	OFF	ON	OFF	ON	OFF	ON	OFF
85	ON	OFF	ON	OFF	ON	OFF	ON	OFF
86	OFF	ON	ON	OFF	ON	OFF	ON	OFF
87	ON	ON	ON	OFF	ON	OFF	ON	OFF
88	OFF	OFF	OFF	ON	ON	OFF	ON	OFF
89	ON	OFF	OFF	ON	ON	OFF	ON	OFF
90	OFF	ON	OFF	ON	ON	OFF	ON	OFF
91	ON	ON	OFF	ON	ON	OFF	ON	OFF
92	OFF	OFF	ON	ON	ON	OFF	ON	OFF
93	ON	OFF	ON	ON	ON	OFF	ON	OFF
94	OFF	ON	ON	ON	ON	OFF	ON	OFF
95	ON	ON	ON	ON	ON	OFF	ON	OFF
96	OFF	OFF	OFF	OFF	OFF	ON	ON	OFF
97	ON	OFF	OFF	OFF	OFF	ON	ON	OFF
98	OFF	ON	OFF	OFF	OFF	ON	ON	OFF
99	ON	ON	OFF	OFF	OFF	ON	ON	OFF
100	OFF	OFF	ON	OFF	OFF	ON	ON	OFF
101	ON	OFF	ON	OFF	OFF	ON	ON	OFF
102	OFF	ON	ON	OFF	OFF	ON	ON	OFF
103	ON	ON	ON	OFF	OFF	ON	ON	OFF
104	OFF	OFF	OFF	ON	OFF	ON	ON	OFF
105	ON	OFF	OFF	ON	OFF	ON	ON	OFF
106	OFF	ON	OFF	ON	OFF	ON	ON	OFF
107	ON	ON	OFF	ON	OFF	ON	ON	OFF
108	OFF	OFF	ON	ON	OFF	ON	ON	OFF
109	ON	OFF	ON	ON	OFF	ON	ON	OFF
110	OFF	ON	ON	ON	OFF	ON	ON	OFF
111	ON	ON	ON	ON	OFF	ON	ON	OFF
112	OFF	OFF	OFF	OFF	ON	ON	ON	OFF
113	ON	OFF	OFF	OFF	ON	ON	ON	OFF
114	OFF	ON	OFF	OFF	ON	ON	ON	OFF
115	ON	ON	OFF	OFF	ON	ON	ON	OFF
116	OFF	OFF	ON	OFF	ON	ON	ON	OFF
117	ON	OFF	ON	OFF	ON	ON	ON	OFF
118	OFF	ON	ON	OFF	ON	ON	ON	OFF
119	ON	ON	ON	OFF	ON	ON	ON	OFF
120	OFF	OFF	OFF	ON	ON	ON	ON	OFF
121	ON	OFF	OFF	ON	ON	ON	ON	OFF
122	OFF	ON	OFF	ON	ON	ON	ON	OFF
123	ON	ON	OFF	ON	ON	ON	ON	OFF
124	OFF	OFF	ON	ON	ON	ON	ON	OFF
125	ON	OFF	ON	ON	ON	ON	ON	OFF

Figure 4.3 – Setting Dome Camera Address (ID)

DOME ID	D1 (1)	D2 (2)	D3 (4)	D4 (8)	D5 (16)	D6 (32)	D7 (64)	D8 (128)
126	OFF	ON	ON	ON	ON	ON	ON	OFF
127	ON	ON	ON	ON	ON	ON	ON	OFF
128	OFF	OFF	OFF	OFF	OFF	OFF	OFF	ON
129	ON	OFF	OFF	OFF	OFF	OFF	OFF	ON
130	OFF	ON	OFF	OFF	OFF	OFF	OFF	ON
131	ON	ON	OFF	OFF	OFF	OFF	OFF	ON
132	OFF	OFF	ON	OFF	OFF	OFF	OFF	ON
133	ON	OFF	ON	OFF	OFF	OFF	OFF	ON
134	OFF	ON	ON	OFF	OFF	OFF	OFF	ON
135	ON	ON	ON	OFF	OFF	OFF	OFF	ON
136	OFF	OFF	OFF	ON	OFF	OFF	OFF	ON
137	ON	OFF	OFF	ON	OFF	OFF	OFF	ON
138	OFF	ON	OFF	ON	OFF	OFF	OFF	ON
139	ON	ON	OFF	ON	OFF	OFF	OFF	ON
140	OFF	OFF	ON	ON	OFF	OFF	OFF	ON
141	ON	OFF	ON	ON	OFF	OFF	OFF	ON
142	OFF	ON	ON	ON	OFF	OFF	OFF	ON
143	ON	ON	ON	ON	OFF	OFF	OFF	ON
144	OFF	OFF	OFF	OFF	ON	OFF	OFF	ON
145	ON	OFF	OFF	OFF	ON	OFF	OFF	ON
146	OFF	ON	OFF	OFF	ON	OFF	OFF	ON
147	ON	ON	OFF	OFF	ON	OFF	OFF	ON
148	OFF	OFF	ON	OFF	ON	OFF	OFF	ON
149	ON	OFF	ON	OFF	ON	OFF	OFF	ON
150	OFF	ON	ON	OFF	ON	OFF	OFF	ON
151	ON	ON	ON	OFF	ON	OFF	OFF	ON
152	OFF	OFF	OFF	ON	ON	OFF	OFF	ON
153	ON	OFF	OFF	ON	ON	OFF	OFF	ON
154	OFF	ON	OFF	ON	ON	OFF	OFF	ON
155	ON	ON	OFF	ON	ON	OFF	OFF	ON
156	OFF	OFF	ON	ON	ON	OFF	OFF	ON
157	ON	OFF	ON	ON	ON	OFF	OFF	ON
158	OFF	ON	ON	ON	ON	OFF	OFF	ON
159	ON	ON	ON	ON	ON	OFF	OFF	ON
160	OFF	OFF	OFF	OFF	OFF	ON	OFF	ON
161	ON	OFF	OFF	OFF	OFF	ON	OFF	ON
162	OFF	ON	OFF	OFF	OFF	ON	OFF	ON
163	ON	ON	OFF	OFF	OFF	ON	OFF	ON
164	OFF	OFF	ON	OFF	OFF	ON	OFF	ON
165	ON	OFF	ON	OFF	OFF	ON	OFF	ON
166	OFF	ON	ON	OFF	OFF	ON	OFF	ON
167	ON	ON	ON	OFF	OFF	ON	OFF	ON
168	OFF	OFF	OFF	ON	OFF	ON	OFF	ON
169	ON	OFF	OFF	ON	OFF	ON	OFF	ON
170	OFF	ON	OFF	ON	OFF	ON	OFF	ON

Figure 4.4 – Setting Dome Camera Address (ID)

DOME ID	D1 (1)	D2 (2)	D3 (4)	D4 (8)	D5 (16)	D6 (32)	D7 (64)	D8 (128)
171	ON	ON	OFF	ON	OFF	ON	OFF	ON
172	OFF	OFF	ON	ON	OFF	ON	OFF	ON
173	ON	OFF	ON	ON	OFF	ON	OFF	ON
174	OFF	ON	ON	ON	OFF	ON	OFF	ON
175	ON	ON	ON	ON	OFF	ON	OFF	ON
176	OFF	OFF	OFF	OFF	ON	ON	OFF	ON
177	ON	OFF	OFF	OFF	ON	ON	OFF	ON
178	OFF	ON	OFF	OFF	ON	ON	OFF	ON
179	ON	ON	OFF	OFF	ON	ON	OFF	ON
180	OFF	OFF	ON	OFF	ON	ON	OFF	ON
181	ON	OFF	ON	OFF	ON	ON	OFF	ON
182	OFF	ON	ON	OFF	ON	ON	OFF	ON
183	ON	ON	ON	OFF	ON	ON	OFF	ON
184	OFF	OFF	OFF	ON	ON	ON	OFF	ON
185	ON	OFF	OFF	ON	ON	ON	OFF	ON
186	OFF	ON	OFF	ON	ON	ON	OFF	ON
187	ON	ON	OFF	ON	ON	ON	OFF	ON
188	OFF	OFF	ON	ON	ON	ON	OFF	ON
189	ON	OFF	ON	ON	ON	ON	OFF	ON
190	OFF	ON	ON	ON	ON	ON	OFF	ON
191	ON	ON	ON	ON	ON	ON	OFF	ON
192	OFF	OFF	OFF	OFF	OFF	OFF	ON	ON
193	ON	OFF	OFF	OFF	OFF	OFF	ON	ON
194	OFF	ON	OFF	OFF	OFF	OFF	ON	ON
195	ON	ON	OFF	OFF	OFF	OFF	ON	ON
196	OFF	OFF	ON	OFF	OFF	OFF	ON	ON
197	ON	OFF	ON	OFF	OFF	OFF	ON	ON
198	OFF	ON	ON	OFF	OFF	OFF	ON	ON
199	ON	ON	ON	OFF	OFF	OFF	ON	ON
200	OFF	OFF	OFF	ON	OFF	OFF	ON	ON
201	ON	OFF	OFF	ON	OFF	OFF	ON	ON
202	OFF	ON	OFF	ON	OFF	OFF	ON	ON
203	ON	ON	OFF	ON	OFF	OFF	ON	ON
204	OFF	OFF	ON	ON	OFF	OFF	ON	ON
205	ON	OFF	ON	ON	OFF	OFF	ON	ON
206	OFF	ON	ON	ON	OFF	OFF	ON	ON
207	ON	ON	ON	ON	OFF	OFF	ON	ON
208	OFF	OFF	OFF	OFF	ON	OFF	ON	ON
209	ON	OFF	OFF	OFF	ON	OFF	ON	ON
210	OFF	ON	OFF	OFF	ON	OFF	ON	ON
211	ON	ON	OFF	OFF	ON	OFF	ON	ON
212	OFF	OFF	ON	OFF	ON	OFF	ON	ON
213	ON	OFF	ON	OFF	ON	OFF	ON	ON
214	OFF	ON	ON	OFF	ON	OFF	ON	ON
215	ON	ON	ON	OFF	ON	OFF	ON	ON

Figure 4.5 – Setting Dome Camera Address (ID)

DOME ID	D1 (1)	D2 (2)	D3 (4)	D4 (8)	D5 (16)	D6 (32)	D7 (64)	D8 (128)
216	OFF	OFF	OFF	ON	ON	OFF	ON	ON
217	ON	OFF	OFF	ON	ON	OFF	ON	ON
218	OFF	ON	OFF	ON	ON	OFF	ON	ON
219	ON	ON	OFF	ON	ON	OFF	ON	ON
220	OFF	OFF	ON	ON	ON	OFF	ON	ON
221	ON	OFF	ON	ON	ON	OFF	ON	ON
222	OFF	ON	ON	ON	ON	OFF	ON	ON
223	ON	ON	ON	ON	ON	OFF	ON	ON
224	OFF	OFF	OFF	OFF	OFF	ON	ON	ON
225	ON	OFF	OFF	OFF	OFF	ON	ON	ON
226	OFF	ON	OFF	OFF	OFF	ON	ON	ON
227	ON	ON	OFF	OFF	OFF	ON	ON	ON
228	OFF	OFF	ON	OFF	OFF	ON	ON	ON
229	ON	OFF	ON	OFF	OFF	ON	ON	ON
230	OFF	ON	ON	OFF	OFF	ON	ON	ON
231	ON	ON	ON	OFF	OFF	ON	ON	ON
232	OFF	OFF	OFF	ON	OFF	ON	ON	ON
233	ON	OFF	OFF	ON	OFF	ON	ON	ON
234	OFF	ON	OFF	ON	OFF	ON	ON	ON
235	ON	ON	OFF	ON	OFF	ON	ON	ON
236	OFF	OFF	ON	ON	OFF	ON	ON	ON
237	ON	OFF	ON	ON	OFF	ON	ON	ON
238	OFF	ON	ON	ON	OFF	ON	ON	ON
239	ON	ON	ON	ON	OFF	ON	ON	ON
240	OFF	OFF	OFF	OFF	ON	ON	ON	ON
241	ON	OFF	OFF	OFF	ON	ON	ON	ON
242	OFF	ON	OFF	OFF	ON	ON	ON	ON
243	ON	ON	OFF	OFF	ON	ON	ON	ON
244	OFF	OFF	ON	OFF	ON	ON	ON	ON
245	ON	OFF	ON	OFF	ON	ON	ON	ON
246	OFF	ON	ON	OFF	ON	ON	ON	ON
247	ON	ON	ON	OFF	ON	ON	ON	ON
248	OFF	OFF	OFF	ON	ON	ON	ON	ON
249	ON	OFF	OFF	ON	ON	ON	ON	ON
250	OFF	ON	OFF	ON	ON	ON	ON	ON
251	ON	ON	OFF	ON	ON	ON	ON	ON
252	OFF	OFF	ON	ON	ON	ON	ON	ON
253	ON	OFF	ON	ON	ON	ON	ON	ON
254	OFF	ON	ON	ON	ON	ON	ON	ON
255	ON	ON	ON	ON	ON	ON	ON	ON

Figure 4.6 – Setting Dome Camera Address (ID)

2.6 Setting Dome Camera Protocol and Video

If a dome camera is to be installed with the keyboard controller, select the default protocol.

Consult service personnel if a dome camera is installed with device other than a keyboard controller.

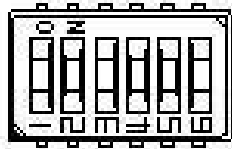

S2

You can set video type with dip switch.

Select video type with D1 in S2

S2-D1	VIDEO TYPE
OFF	NTSC
ON	PAL

You can set Protocol with dip switch D2, D3 and D4 in S2.

S2			PROTOCOL
D2	D3	D4	
OFF	OFF	OFF	F2, F2E, Pelco-P, Pelco-D : default
OFF	OFF	ON	F2, F2E
OFF	ON	ON	Pelco-P, Pelco-D

You can set Baud Rate with dip switch D5 and D6 in S2.

S2		BAUD RATE
D5	D6	
OFF	OFF	2400 bps
OFF	ON	4800 bps
ON	OFF	9600 bps : default
ON	ON	19200 bps

Figure 5 – Video type, Protocol, Baud rate Selection Switches

2.7 Connections

• Connecting to the RS485

The dome camera can be controlled remotely by an external device or control system, such as a control keyboard, using RS485 half-duplex serial communications signals.

• Connecting Video out connector

Connect the video out (BNC) connector to the monitor or video input.

- **Connecting Alarms**

AI (Alarm In)

You can use external devices to signal the dome camera to react on events. Mechanical or electrical switches can be wired to the AI (Alarm In) and G (Ground) connectors.

See Chapter 3 — Program and Operation for configuring alarm input.

G (Ground)

NOTE: All the connectors marked G or GND are common.

Connect the ground side of the alarm input and/or alarm output to the G (Ground) connector.

AO (Alarm Output)

The dome camera can activate external devices such as buzzers or lights. Connect the device to the AO (Alarm Out) and G (Ground) connectors.

See Chapter 3 — Program and Operation for configuring alarm output.

- **Connecting the Power of Dome**

Connect the power of AC 24V or DC12V 1A for the dome camera.

When using a DC 12V adapter, connector the positive(+) pole to the '+' position and the negative(-) pole to the '-' position.

Use certified / Listed Class 2 power source only.

- **Connecting the Power of Heater & Fan**

Connect the power of AC 24V 2A for the heater & fan.

Use certified / Listed Class 2 power source only.

2.8 Getting Started

Once installed apply power to the dome camera. The dome camera will start a configuration sequence.

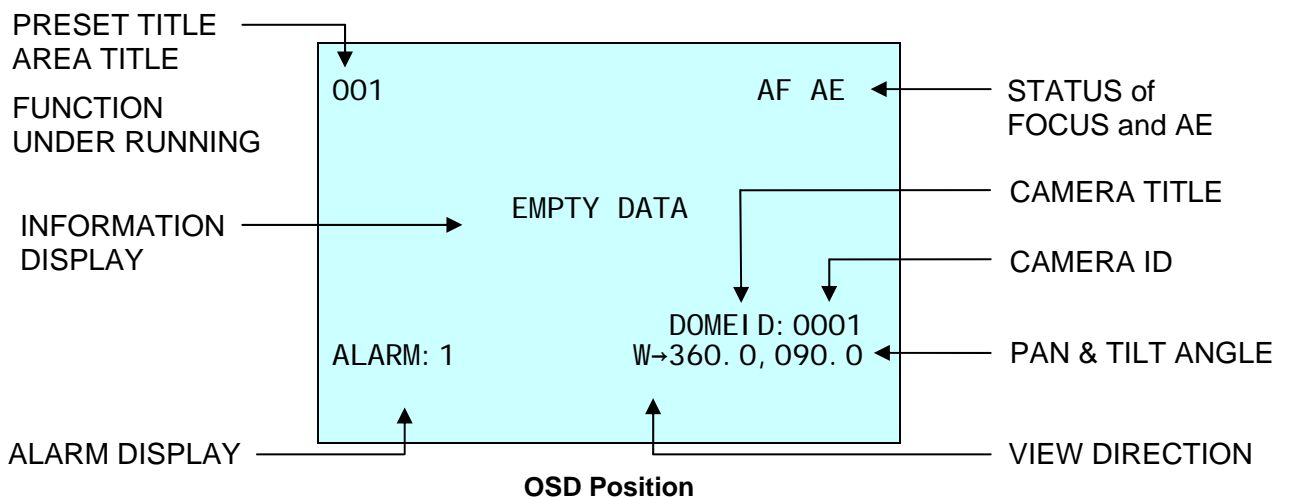

The dome can move the OSD position in the OSD position setup.

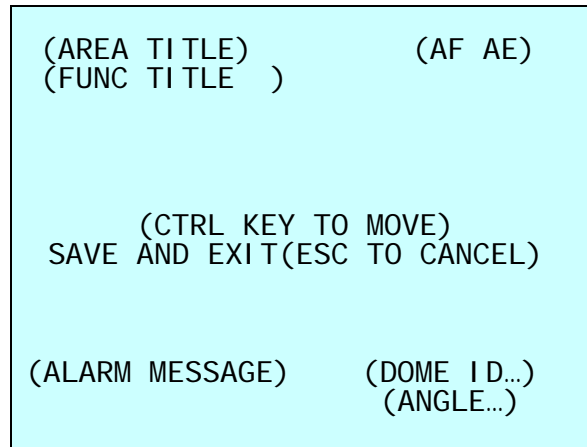

OSD Position Setup

Chapter 3 — Program and Operation

3.1 Dome Camera Selection

Before you program or operate a dome camera, you must select the dome camera by pressing **No.** + **CAM** keys.

Example: Pressing **1**, **0** + **CAM** keys sequentially will select dome camera 10. The selected dome camera ID will be displayed on the LCD monitor of the keyboard controller.

3.2 Accessing the On-Screen Menu Utility

You can call up the On-screen menu utility on your monitor by pressing the **MENU** key on the keyboard controller, the following On-screen menu utility will appear:

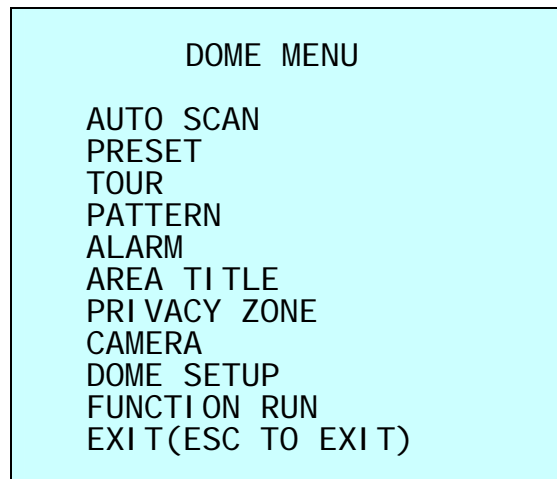

3.3 How to control the On-Screen Menu Utility

Function	Button
Call the On-screen menu utility	MENU
Navigate through the menu items.	Joystick up or down
Go into the sub-menu items.	Joystick left or right or IRIS Open
Change value. Enter the editing title mode.	Joystick left or right or Zoom handle twist or Tele , Wide
Change value of angle	CTRL + Joystick
Enter the changing angle mode.	IRIS Open
Exit the changing angle mode.	IRIS Close
Escape (EXIT)	ESC

3.4 Auto Scan (Shortcut: **SCAN**)

The Auto Scan supports up to 5 programmed angles at user-programmable speeds. Follow these steps to program Auto Scan:

AUTO SCAN SETUP	
NUMBER	: 01
TITLE	: A01
MODE	: NORMAL
SPEED	: 5 STEP
START ANGLE	: -----
END ANGLE	: -----
SCAN DIR	: CCW
SWAP	: OFF
DWELL	: 03 SEC
SAVE AND EXIT (ESC TO CANCEL)	

- NUMBER** : 01~04, **09**:AUTO PAN mode.
TITLE : up to 12 characters.
MODE : NORMAL, VECTOR, RANDOM (AUTO PAN mode: NORMAL, RANDOM only).
 NORMAL : Move from start point to end point in panning only.
 VECTOR : Move from start point to end point including tilt and zoom simultaneously and linearly.
 RANDOM : Move randomly between the start point and the end point.
- SPEED** : 01~13 step, the lower number means the slower speed.
SCAN DIR : Set the Scan direction, CCW(Counter Clock Wise), CW(Clock Wise).
SWAP : Swap the start point for the end point.
DWELL : Set the dwell time at the both end, 01~99 seconds.

1. Press the **SCAN** key to enter the Auto Scan menu directly. Or press the **MENU** key to display the main menu on the monitor. Scroll to Auto Scan and push the **Joystick** to the right.
2. Select "NUMBER" and set the desired number by pushing the **Joystick** to the left or right.

3. Select "TITLE" and twist the **Joystick** to enter the title edit mode.
4. Twist the **Joystick** by changing the alphanumeric characters and move the next position. Or move down to the character table and press the **CTRL** or **IRIS Open** key at the desired character then the cursor position moves to the next position automatically. Push the **Joystick** to the left or right at the "ALL DELETE" field to delete all characters. Push the **Joystick** to the left or right at the "EXIT" field to finish title edit menu.

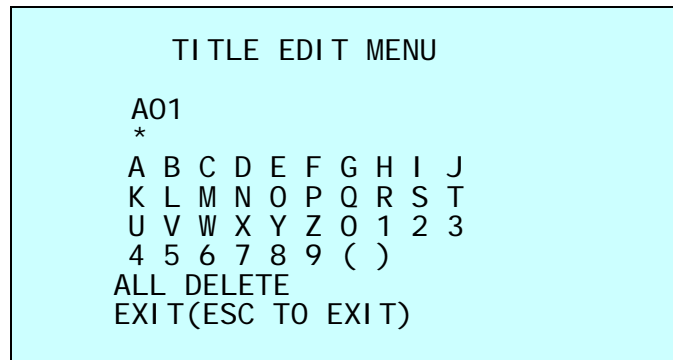

5. Select "MODE" and "SPEED".
6. Select "START ANGLE". Hold down the **CTRL** key while selecting the start position using the **Joystick**. Current panning position will be displayed. Release the **CTRL** key to complete the selection of the start position. Or press the **IRIS Open** key then the "CTRL" displays. Move the desired position and the zoom position. Press the **IRIS Close** key then the "CTRL" disappears. To adjust at the 0.1 degree interval, twist the **Joystick** at the pan field and the tilt field. To adjust at the one zoom interval, twist the **Joystick** at the zoom field.
7. Select "END ANGLE." Hold down the **CTRL** key while moving the **Joystick** to select the end position. The end position angle should be larger than start position. Release the **CTRL** key to complete the selection of the end position. Or press the **IRIS Open** key then the "CTRL" displays. Move the desired position and the zoom position. Press the **IRIS Close** key then the "CTRL" disappears. To adjust at the 0.1 degree interval, twist the **Joystick** at the pan field and the tilt field. To adjust at the one zoom interval, twist the **Joystick** at the zoom field.
8. Set "SCAN DIR" to CCW or CW.
9. Select "SWAP", Set to ON, to exchange the start angle and the end angle.
10. Set "DWELL TIME".
11. Select "SAVE & EXIT" and push the **Joystick** to the right or press the **IRIS Open** key. Press the **ESC** or **IRIS Close** key to exit the program without saving.

NOTE: Pressing the **HOME key delete stored data at the angle field.**

To set the position using the Preset position:

- a. Before entering the Auto Scan menu, select a Preset position as a starting point for Auto Scan.

Example: **2** + **PRST** keys and do step 1 to 5. In step 6, just press the **Ctrl** key at the start angle position, the current position will be displayed as a start position.

- b. Save and exit from the menu.

- c. In normal mode, call a Preset to be the end point of Scan. Press **3** + **PRST** keys then press the **SCAN** key to enter the Auto Scan menu. Move the cursor position to END ANGLE. Just press the **CTRL** key at the end angle position. Save and exit from the menu.

Press the **SCAN** key on the angle field to display with the small OSD. Then the screen will show as below.

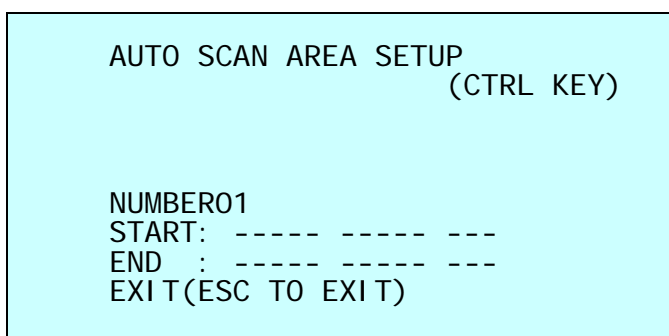

The setting procedure is the same as above.

NOTE: 09:AUTO-PAN mode (Endless panning)

3.5 Preset (Shortcut: **PRST**)

If you need to view specific places routinely, you should program Presets. A Preset is a programmed video scene with automatic pan, tilt, zoom, focus, and AE settings. Once programmed, placing the number position and pressing the **PRST** key on your controller calls up that Preset automatically. In addition, Presets may be assigned to alarm action or as the “home” position for the dome camera. As many as 120 Presets, whose positions are saved in the dome’s firmware, may be programmed.

There are two pages of Preset menu. Each page has 60 Presets. Pages can be scrolled by pushing the **Joystick** to the left or right on the first or last No. of Preset.

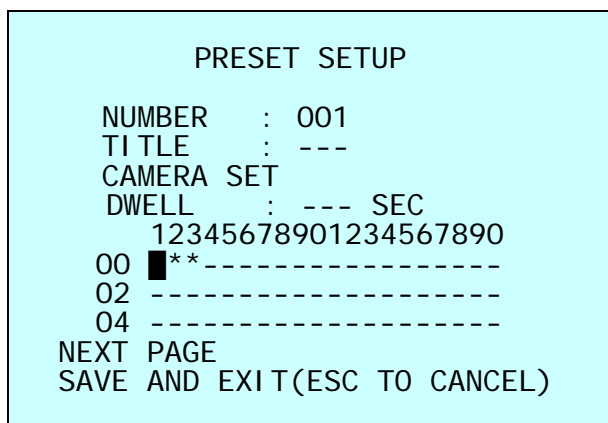

- : blank Preset position
- * : position has the Preset
- : current cursor position

Follow steps below to store the Preset positions:

1. Press the **PRST** key to enter the Preset menu directly. Or press the **MENU** key to display the main menu on the monitor. Scroll to Preset and push the **Joystick** to the right.
2. Select the blank Preset position to be stored by pushing the **Joystick** up, down, right, or left.

3. After selecting a blank position, press and hold the **CTRL** key. Use the **Joystick** to control the direction of the camera and lens.
4. After aiming the camera (view direction and lens control), release the **CTRL** key. The cursor will be on the Title after saving data then twist the **Joystick** or press the **Tele** or **Wide** key to edit the Preset title. Follow the procedure of the Auto Scan above to edit titles.
5. Select "CAMERA SET" and pushing the **Joystick** to the left or right. Then the Preset camera setup displays.

```

PRESET CAMERA SETUP

FOCUS      : AUTO
MOTION     : OFF
MOTION SETUP
AE SETUP
SAVE AND EXIT(ESC TO CANCEL)

```

Set FOCUS : AUTO, MANUAL, ONE PUSH
Set MOTION : OFF, ON

Select "MOTION SETUP" and pushing the **Joystick** to the left or right. Then the MOTION setup displays.

```

MOTION SETUP

SENSITIVITY : 07
POSITION    : ALL
DELAY       : 00 SEC
OUTPUT      : OFF
HOLD TIME   : 03 SEC
EXIT(ESC TO EXIT)

```

Set SENSITIVITY : 01~10
Set POSITION : ALL, CENTER
Set DELAY : 0~5 SEC
Set OUTPUT : OFF, ON
Set HOLD TIME : 03~99 SEC

Select "AE SETUP" and pushing the **Joystick** to the left or right. Then the AE setup displays. Refer to the AE SETUP in the camera setup.

6. Set "DWEELL TIME" (03~99 seconds)
7. To select the next page of Presets, scroll the page by pushing the **Joystick** to the left on the first and last columns of the menu.
8. Repeat step 2 through 7 for each additional Preset position.
9. Select "EXIT" and push the **Joystick** to the right or press the **IRIS Open** key. Press the **ESC** or **IRIS Close** key to exit the program without saving.

NOTE: Press the **HOME key at programmed Preset position(*) to delete a programmed Preset view.**

The position, which is marked with the *, already has the Preset view assigned. To review the stored Preset, press the **PRST** key on the *. The camera will show the stored Preset scene.

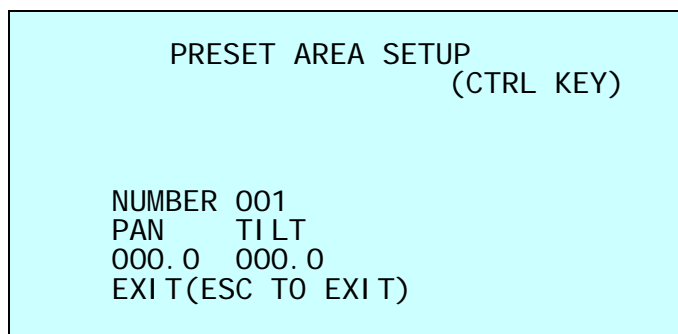

Hold down the **CTRL** key while selecting the desired scene using the **Joystick**. Current position will be displayed. Release the **CTRL** key to complete. Or Press the **IRIS Open** key then the “CTRL” displays. Move the desired position and the zoom position. Press the **IRIS Close** key then the “CTRL” disappears. Select “EXIT” and push the **Joystick** to the right.

3.6 Shortcut of Preset Program

After selecting the desired scene, press No. (1 to 120), and press the **CTRL** and **PRST** keys subsequently. The current view will be stored to the selected Preset number if the Preset number is empty. If selected Preset number is not empty, “OVER WRITE” message will be displayed on the monitor and select the “OK” and push the **Joystick** to the right to overwrite.

Example: **1**, **0**, **1** + **CTRL** + **PRST** keys will store current view as Preset no. **101**. In this case, focus will be programmed as Auto, dwell time will be set to 3 second, and the current AE mode will be programmed.

3.7 Tour (Shortcut: **TOUR**)

There are 4 programmable Tours. Each Tour consists of up to 42 Preset positions, Patterns, Scans or other Tours (second-level). Using second-level Tours, it can be expanded to over 150 functions in a single Tour.

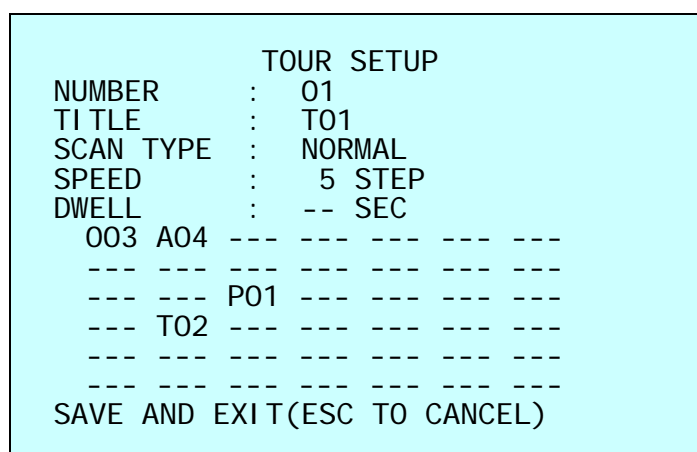

--- : blank position
 SCAN TYPE : NORMAL, VECTOR
 DWELL : 03~99 SEC
 003 : Preset (1~120)
 A04 : Auto Scan (1~4)
 P01 : Pattern (1~4)
 T02 : Tour (1~4)

Follow the steps below to program the Tours:

1. Press the **MENU** key to display the main menu on the monitor. Scroll to Tour and push the **Joystick** to the right to enter the Tour menu. Or just press the **TOUR** key on the keyboard.
2. Select "NUMBER" and set the desired number by pushing the **Joystick** to the left or right.
3. Choose a blank position to be programmed by pushing the **Joystick** up, down, right, or left.
4. To add a stored Preset, twist the **Joystick** then the stored Preset number displays.
5. To place functions other than Preset, press the **TOUR**, **PTRN**, or **SCAN** keys for Tour, Pattern or Auto Scan respectively.
6. You can also overwrite the programmed number and to remove a stored number from the Tour, press the **HOME** key on the stored number, a blank position mark (---) will be displayed.
7. Repeat step 2 through 5 for each desired position. Each title will be displayed on top of the line.
8. To edit the title, follow the procedure of the Auto Scan above to edit titles.
9. Select "SAVE & EXIT" and push the **Joystick** to the right or press the **IRIS Open** key. Press the **ESC** or **IRIS Close** key to exit the program without saving.

You can expand the Tour sequence by calling other programmed Tours.

NOTE: The speed applies in the vector mode only.

NOTE: In the Tour mode, in conjunction with Preset and Auto Scan, you can make the camera travel from a Preset position to another Preset position at a specific speed.

Example: Preset 001>002>003>004>005>006, Auto Scan 01 starts at Preset 002, ends at Preset 003, Auto Scan 02 starts at Preset 005, ends at Preset 006; Tour 001, 002, A01, 004, A02.

1 → 2 2~3 → 4 → 5~6, repeat
where → : Quick move, ~ : Programmed speed

To change the dwell time of the Preset in the Tour:

Use the **Joystick** to move the cursor to a stored Preset position.

By pressing the **PRST** key, the camera will move to the stored Preset view and the cursor moves to the dwell time field.

After changing the dwell time, press the **PRST** key and the cursor moves to the Preset number.

To assign the functions other than Preset in the Tour when the function key is not existed:

Use the **Joystick** to move the cursor to a stored Preset position.

Pressing the **CTRL** or **IRIS Open** key will change the Preset number to other function (Auto Scan, Pattern, Tour, Preset) with the first programmed number.

To change the number, twist the **Joystick** or press the **Tele** or **Wide** key.

3.8 Pattern (Shortcut: **PTRN**)

The Pattern feature records user control of the selected dome camera. Up to 4 Patterns can be stored and played back by pressing **No.** + **PTRN** keys subsequently.

PATTERN SETUP			
(CTRL KEY)			
NO	TITLE	SEC	PERCENT
01 :	P01	000	00.0%
02 :	P02	000	00.0%
03 :	P03	000	00.0%
04 :	P04	000	00.0%
TOTAL		0000	00.0%
SAVE AND EXIT(ESC TO CANCEL)			

Follow steps below to program the Pattern:

1. Press the **MENU** key to display the main menu on the monitor. Scroll to Pattern and push the **Joystick** to the right to enter the Pattern menu. Or just press the **PTRN** key on the keyboard.
2. Select the desired Pattern to be programmed by pushing the **Joystick** up or down. If the Pattern is not 000, a Pattern has already been recorded. Patterns can be overwritten.
3. Press and hold down the **CTRL** key while controlling the camera direction and zoom with the **Joystick**. The dome will be automatically recorded until you release the **CTRL** key. Or press the **IRIS Open** key then the "CTRL" displays. Move the position and the zoom position. Press the **IRIS Close** key then the "CTRL" disappears.
4. Select "SAVE & EXIT" and push the **Joystick** to the right or press the **IRIS Open** key. Press the **ESC** or **IRIS Close** key to exit the program without saving.
5. To edit the title, follow the procedure of the Auto Scan above to edit titles.

NOTE: Press the **HOME key at any programmed position to delete the Pattern.**

NOTE: If Pattern recording time reaches 200 seconds, it will automatically stop for a moment.

PATTERN AREA SETUP	
(CTRL KEY)	
NUMBER 01	
000	00.0%
001	01.0%
EXIT(ESC TO EXIT)	

Press the **PTRN** key on the title field to display with the small OSD. Then the screen will show as below.

The setting procedure is the same as above.

3.9 Alarm

```

ALARM SETUP

NO PRI FUN IN  OUT HLD LATCH
01  1  001 NC  ON  03  OFF

ALARM OUT SETUP
SAVE AND EXIT(ESC TO CANCEL)

```

- NO** : alarm input number
- PRI(Priority)** : The lower number has higher priority. (1 fixed)
- FUN(Function)** : Stored function number to be called by alarm.
- IN** : NO/NC - normally open/closed, OFF - ignore
- OUT** : ON – TTL output on, OFF – No output.
- HLD(Hold)** : Alarm will be held for programmed time (03 to 99 seconds)
- LATCH** : ON – Alarm message will remain on the screen even though alarm input is deactivated.
OFF – Alarm message will disappear on the screen after programmed hold time when alarm input is deactivated.

```

ALARM OUT SETUP

OUT      : ALARM

EXIT(ESC TO EXIT)

```

ALARM: alarm output is operated during an alarm operation or by the short key of our keyboard.

1-5 MIN(minute): alarm output is operated during this setting time only by the function run of the dome menu or the short key of our keyboard.

NOTE: This 1-5 MIN setting is not operated by an alarm.

3.10 Area Title

Enter a specific name on programmed angle between START and END. For the screen below, when the camera points at an angle between 124.3° (PAN), 30.7° (TILT) to 359.5° (PAN), 45.4° (TILT), ABC will be displayed on the screen.

```

AREA TITLE SETUP

NUMBER      : 01
TITLE       : ABC
START ANGLE : 124.3  30.7
END ANGLE   : 359.5  45.4
SWAP        : OFF
SAVE AND EXIT(ESC TO CANCEL)

```

- NUMBER** : 01-08
- TITLE** : up to 12 characters.
- SWAP** : Swap the start point for the end point.

1. Select "NUMBER" and set the desired number by pushing the **Joystick** to the left or right.
2. To edit the title, follow the procedure of the Auto Scan above to edit titles.
3. Select "START ANGLE". Hold down the **CTRL** key while selecting the start position using the **Joystick**. Current panning position will be displayed. Release the **CTRL** key to complete the selection of the start position. Or press the **IRIS Open** key then the "CTRL" displays. Move the desired position. Press the **IRIS Close** key then the "CTRL" disappears. To adjust at the 0.1 degree interval, twist the **Joystick** at the pan field and the tilt field.
4. Select "END ANGLE". Hold down the **CTRL** key while moving the **Joystick** to select the end position. Release the **CTRL** key to complete the selection of the end position. Or press the **IRIS Open** key then the "CTRL" displays. Move the desired position. Press the **IRIS Close** key then the "CTRL" disappears. To adjust at the 0.1 degree interval, twist the **Joystick** at the pan field and the tilt field.
5. Select "SWAP". Set to ON, to exchange the start angle and the end angle.
6. Select "SAVE & EXIT" and push the **Joystick** to the right or press the **IRIS Open** key. Press the **ESC** or **IRIS Close** key to exit the program without saving.

3.11 Privacy Zone

Hide up to 4 unwanted scenes in a camera.

PRIVACY ZONE SETUP			
NO	TITLE	(CTRL KEY)	METHOD
01	ABC	ON	BLOCK
02	DEF	ON	V. OFF
03		OFF	----
04		OFF	----

SAVE AND EXIT(ESC TO CANCEL)

1. Place the cursor at the title field.
2. Hold down the **CTRL** key displays the privacy area menu while selecting the position using the **Joystick**. Current position will be displayed. Release the **CTRL** key to complete the selection of the position.
Or press the **IRIS Open** key then the privacy area menu displays. Move the desired position. Press the **IRIS Close** key then the "CTRL" disappears and returns to the previous menu.

PRIVACY AREA MENU		
(CTRL KEY)		
		CONTROL
NUMBER	001	
354.8	344.8	

3. Place the cursor at the title field. Twist the **Joystick** to enter the title edit mode. Follow the procedure of the Auto Scan above to edit titles.

4. To turn the stored zone On or Off, twist the **Joystick** or press the **Tele** or **Wide** key.
5. Set the method, "BLOCK" or "V.OFF(video off)".
6. Select "SAVE & EXIT" and push the **Joystick** to the right or press the **IRIS Open** key. Press the **ESC** or **IRIS Close** key to exit the program without saving.

NOTE: Press the HOME key to delete programmed Privacy Zone at the title field.

3.12 Camera Menu

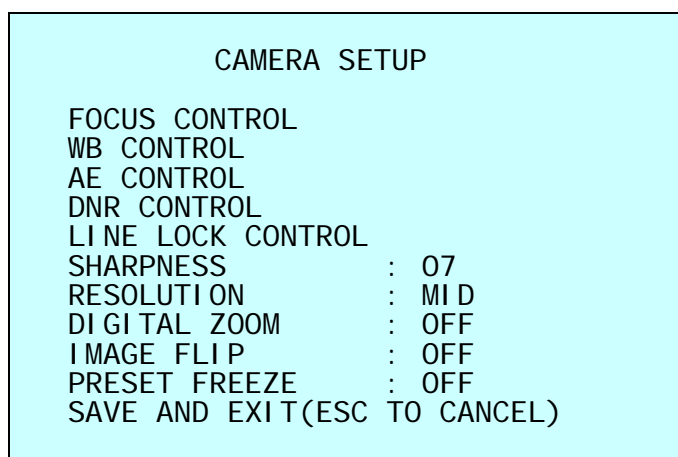

- SHARPNESS** The higher the value, the more edges in the picture will be enhanced. (0~15)
- RESOLUTION** Select high resolution mode. (LOW / MID / HIGH)
- DIGITAL ZOOM** OFF: Zoom range is limited to the optical.
 2X: Zoom is extendable up to 2X of digital range.
 4X: Zoom is extendable up to 4X of digital range.
 8X: Zoom is extendable up to 8X of digital range.
 MAX: Zoom is extendable Max digital zoom range.
- IMAGE FLIP** This function turns the video output from the camera upside down and reverses it horizontally.
This option is helpful to install in the opposite side.
- PRESET FREEZE** ON: the image is frozen during calling Preset.

• FOCUS CONTROL

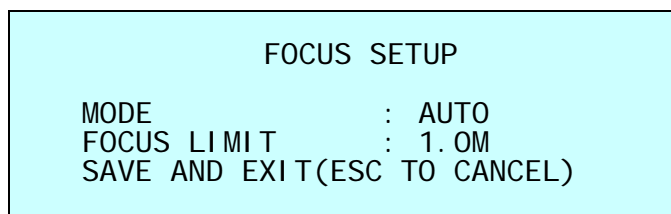

- MODE** AUTO / MANUAL / ONE PUSH / CONSTANT MANUAL
 Use manual mode in normal use.
- FOCUS LIMIT** This distance is approximate value and the focus operate from the setting value.

CAUTION: Avoid continuous, 24-hour use of the auto focus. This will shorten the lifespan of the lens.

• **WB (White Balance) CONTROL**

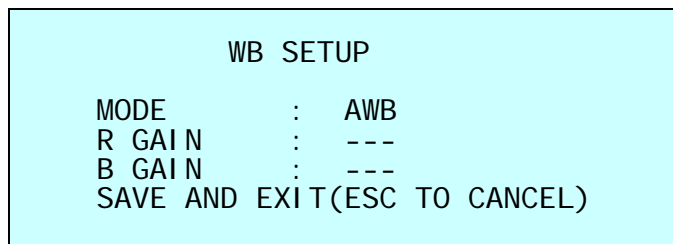

- MODE** AWB / WAWB / INDOOR / OUTDOOR / MANUAL
- AWB Computes the white balance value output using color information from the entire screen automatically. (2500 to 9500 °K)
- WAWB Wide range auto white balance mode. (1800 to 10500 °K)
- INDOOR Indoor white balance mode.
- OUTDOOR Outdoor white balance mode.
- MANUAL Manual mode. You can change R and B Gain manually.
- RGAIN 0~255
- BGAIN 0~255

RGAIN / BGAIN modes are controllable only in MANUAL Mode

• **AE CONTROL**

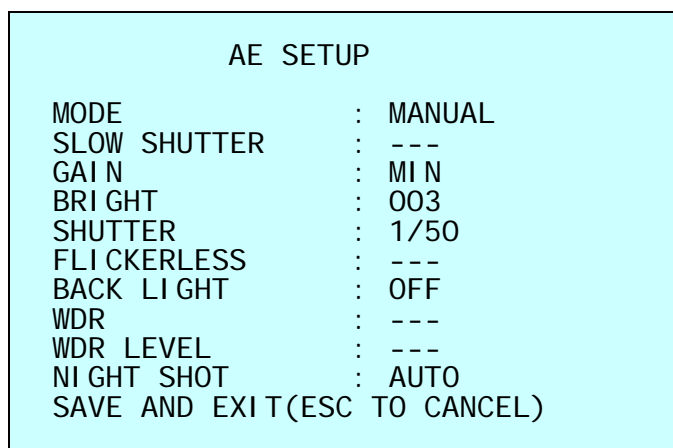

- MODE** AE1 / AE2 / SHUTTER PRIO / MANUAL
- AE1 Auto exposure mode1. (Use to normal surroundings: indoor)
- AE2 Auto exposure mode2. (Use to high brightness surroundings: outdoor)
- SHUTTER PRIO Variable Shutter speed, Auto Gain.
- MANUAL Variable Shutter speed, Gain.
- SLOW SHUTTER** ON / OFF
- GAIN** MIN / LOW / MID / HIGH
- BRIGHT** 0, 1, 2, 3, 4 68, 69, 70
- SHUTTER** 1/50(60), 1/120(100), ..., 1/2000, 1/10000, 1/100000
- FLICKERLESS** ON / OFF
- BACK LIGHT** ON / OFF (**NOTE: When ON, WDR will be disabled.**)
- WDR** ON / OFF (**NOTE: When ON, BACKLIGHT will be disabled.**)
- WDR LEVEL** 10~50
- NIGHT SHOT** AUTO / ON / OFF / GLOBAL

NOTE: Values in () are for NTSC Camera. The WDR operates in AE1 mode only.
NOTE: When BACKLIGHT set ON, bad focus problem might be caused.

The NIGHT SHOT option removes the IR cutoff filter of the camera and makes the camera sensitive to near infrared.

AUTO Camera goes in to B&W mode at low light.

GLOBAL Controlled by the keyboard.

The operator can enable NIGHT SHOT for all dome cameras at the same time.

If the NIGHT SHOT mode is set to GLOBAL, "999" + **ENTER** will turn Off the NIGHT SHOT mode and "888" + **ENTER** will turn On the NIGHT SHOT mode.

ON B/W mode.

OFF Color mode.

NOTE: AUTO in NIGHT SHOT function is not applied in "MANUAL" mode of AE Control.

• DNR CONTROL

DNR CONTROL SETUP	
2DNR(1)	: 001
3DNR(1)	: 010
2DNR(2)	: 001
3DNR(2)	: 003
SAVE AND EXIT(ESC TO CANCEL)	

2DNR(1), 2DNR(2) Select 2D noise reduction level (OFF / 001~007)

3DNR(1), 3DNR(2) Select 3D noise reduction level (OFF / 001~031)

NOTE: DNR(1) applied when motor stopped. DNR(2) applied when motor moving.

• LINE LOCK CONTROL

LINE LOCK SETUP	
MODE	: INTERNAL
PHASE	: 000
SAVE AND EXIT(ESC TO CANCEL)	

MODE INTERNAL / EXTERNAL

PHASE Adjusts phase of picture with other cameras in EXTERNAL mode.(0~259 NTSC, 0~309 PAL)

3.13 Dome Setup

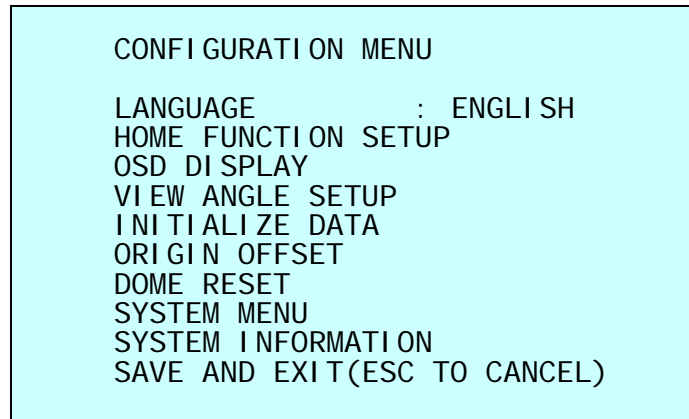

• LANGUAGE SETUP

LANGUAGE : Select the language you want.

• HOME FUNCTION SETUP

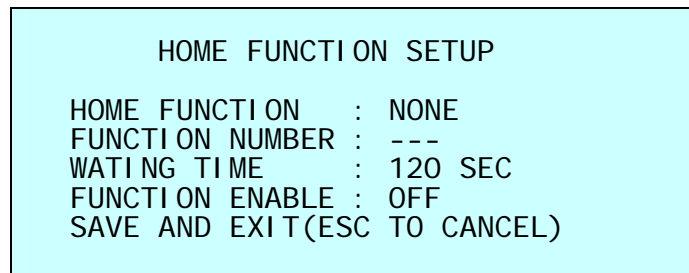

HOME FUNCTION : None / Tour / Pattern / Auto Scan / Preset
FUNCTION NUMBER : ---
WAITING TIME : 10~240 seconds
FUNCTION ENABLE : ON / OFF

The Home function can be set so that the camera automatically goes to Preset, Tour, Pattern, Auto Scan after the keyboard controller has been idle for a amount of time.
For example, if the controller is idle for 120 seconds, the camera goes to Preset 1.

Follow these steps to program the Home position:

1. Select "HOME FUNCTION" by pushing the **Joystick** to the left or right to scroll through the None, Tour, Pattern, Auto Scan or Preset functions.
2. Select "FUNCTION NUMBER" and push the **Joystick** to the left or right. The recorded function number will scroll.
3. Select "WATING TIME" and push the **Joystick** to the left or right to select from 10 to 240 seconds.
4. Select "FUNCTION ENABLE" and turn to ON or OFF by pushing the **Joystick** to the left or right.

• OSD DISPLAY

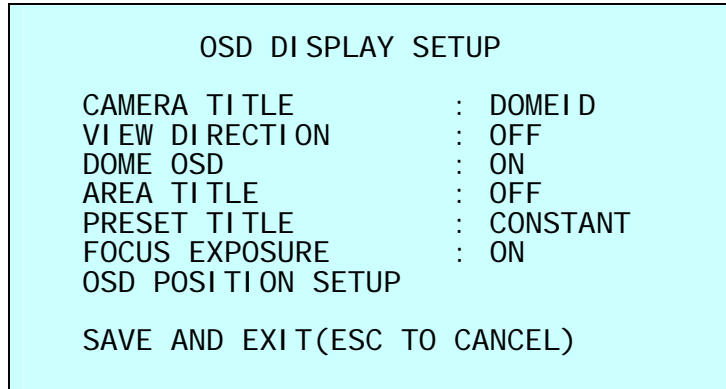

CAMERA TITLE : up to 6 characters.

VIEW DIRECTION : ON / OFF

“ON” sets current direction as N(North) and the coordinate angle to 000. “OFF” hides the directional title. Every 90 degrees of clockwise rotation will change the title to E(East), S(South), W(West). If using the ON/OFF option frequently, it is recommended that you set “North” as a Preset. Recall the “North” Preset before enabling the directional title.

DOME OSD : ON / OFF

All display or title will disappear when DOME OSD DISPLAY sets OFF

AREA TITLE : ON / OFF

If this option is enabled, the area title displays when the camera moves.

NOTE: The DOME OSD DISPLAY must be enabled.

PRESET TITLE : CONSTANT / OFF / 3, 30, 60,120,180 seconds

Set the Preset title display time.

FOCUS EXPOSURE : ON / OFF

ON: FOCUS and EXPOSURE displays. (AF AE)

OSD POSITION SETUP

Select the OSD option with the **Joystick** up and down, press the **CTRL** key and adjust the position by the **Joystick**.

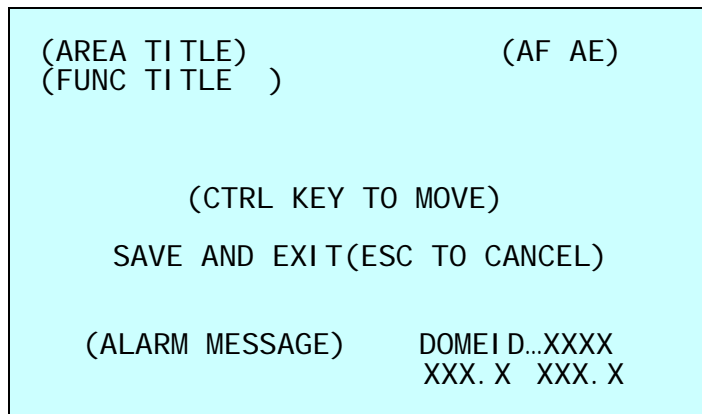

• VIEW ANGLE SETUP

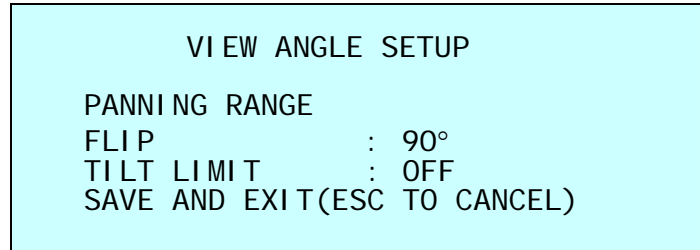

FLIP: OFF, AUTO, 90°, 100°, 110°, 120°,

OFF: the dome camera moves until 90° vertically.

AUTO: When the camera reaches the floor directly above the moving object, it will stop. At that time, release the **Joystick** instantly and pull it down again to run the auto-flip function. When you use the panning range, we recommend using the flip mode to AUTO.

90°, 100°, 110°, 120° : allows the image to flip digitally when the camera moves over the setting angle vertically.

TILT LIMIT:

This option has been designed to limit the view angle as there is some obstruction in zooming out on specific area of the tilt angle.

ON: When this option is enabled, the range of the tilt angle will be limited to 10 degree.

This can prevent from obstruction or bad focus problem caused by the horizontal line of the semi sphere in the bubble.

OFF: When this option is disabled, the range of the tilt angle will not be limited.

When you zoom out within the range of the tilt angle, you will see the horizontal line of the semi sphere in the bubble.

PANNING RANGE

When the dome camera is installed near a wall, panning range can be limited by user.

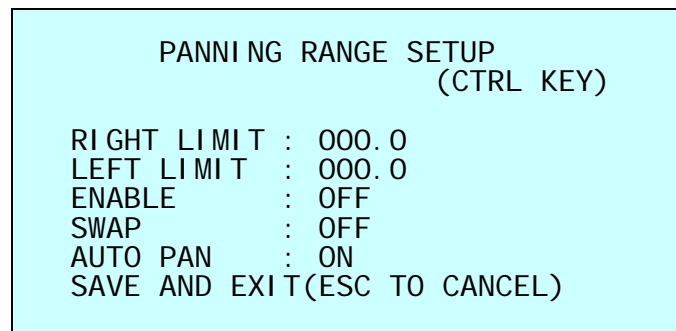

1. Place the dome camera under 90 degree vertically.
2. Set "RIGHT LIMIT" by pushing the **Joystick** to the right.
3. Set the left limit by pushing the **Joystick** to the left.
4. Set ENABLE to ON to use

To exchange the right and the left limit, set SWAP to ON.

To apply limits on the auto pan (endless panning), set AUTO PAN to ON.

NOTE: When the flip mode is 90°, 100°, 110° or 120° and you moves over 90° vertically, the panning range operates in opposite side.

• INITIALIZE DATA

```
INITIALIZE DATA
FACTORY DEFAULT
ERASE PROGRAMMED DATA
PRESET FOCUS DEFAULT
EXIT(ESC TO EXIT)
```

FACTORY DEFAULT

Select "FACTORY DEFAULT" to initialize the Data.

```
FACTORY DEFAULT
ARE YOU SURE ?
CANCEL
OK
```

ERASE PROGRAMMED DATA

Erase all stored data from the Flash-ROM of the selected dome camera. You will be asked to enter ON or OFF. If you desire to erase all data then select "ERASE" run, otherwise press the **ESC** key to exit without erasing. The erased data includes all stored data (Auto Scan, Preset, and Tour....) except origin offset.

The offset value is still valid after all data is erased. The offset value can be zero with default set of Offset origin menu.

```
ERASE PROGRAMMED DATA
AUTO SCAN      : ON
PRESET         : ON
TOUR           : ON
PATTERN        : ON
ALARM          : ON
AREA TITLE     : ON
PRIVACY ZONE   : ON
CAMERA         : ON
DOME SETUP     : ON
ERASE
SAVE AND EXIT(ESC TO CANCEL)
```

PRESET FOCUS DEFAULT

This menu set the default mode of the focus when you save the Preset.

```
PRESET FOCUS DEFAULT
FOCUS          : AUTO
SAVE AND EXIT(ESC TO CANCEL)
```

FOCUS : AUTO / MANUAL / ONE PUSH

• ORIGIN OFFSET

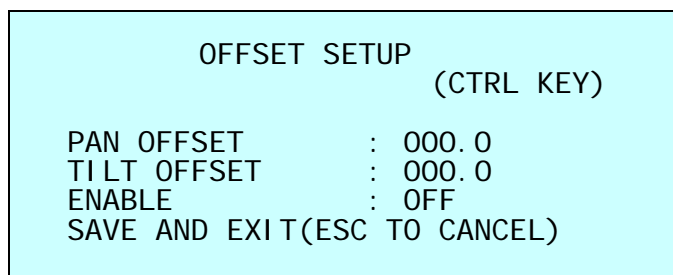

This feature is useful to align a new dome camera exactly the same as the previously installed dome camera.

Dome camera's origin set and all data initialize option do not override offset values. Only the default set option in this menu will set the offset value to zero. This can be used to avoid ceiling obstructions.

• DOME RESET

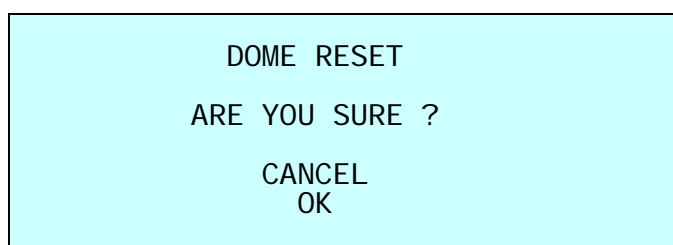

This feature is used to re-calibrate the orientation of a selected dome camera. Origin offset value is not affected by this function. (Offset is still valid after origin set)

• SYSTEM MENU

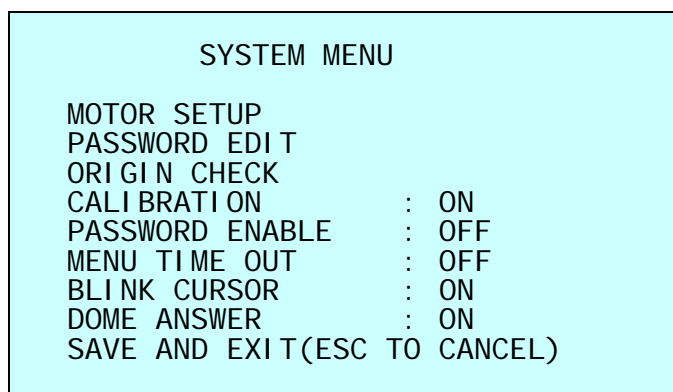

CALIBRATION : ON(Auto origin check) / OFF
PASSWORD ENABLE : ON(requires the password to enter menu) / OFF
MENU TIME OUT : ON(5mintues) / OFF(always menu display)
BLINK CURSOR : ON / OFF(no blinking cursor)
DOME ANSWER : ON / OFF(no acknowledge command from the dome)

This option is helpful to escape the collision of the command using some DVR.

MOTOR SETUP

Motor Setup menu provides the pan and tilt speed of a camera. User can set the desired speed with pushing the **Joystick** to the left or right. During operation, pressing **153** + **ON** keys will change the speed to the SLOW mode and pressing **153** + **OFF** keys will change the speed to the Normal mode.

Press and hold the **CTRL** key and moving the **Joystick** will operate with the TURBO speed mode.

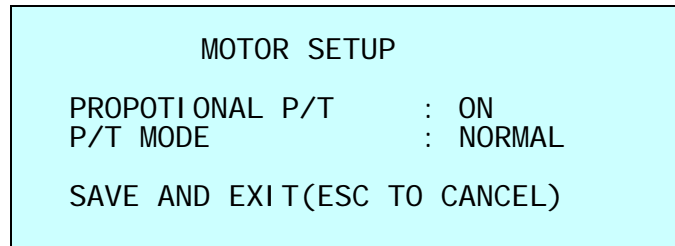

PROPOTIONAL P/T : ON / OFF
P/T MODE : SLOW / NORMAL / TURBO
SLOW MAXIMUM SPEED : 40 ° /second
NORMAL MAXIMUM SPEED : 90 ° /second
TURBO MAXIMUM SPEED : 380 ° /second

PASSWORD EDIT

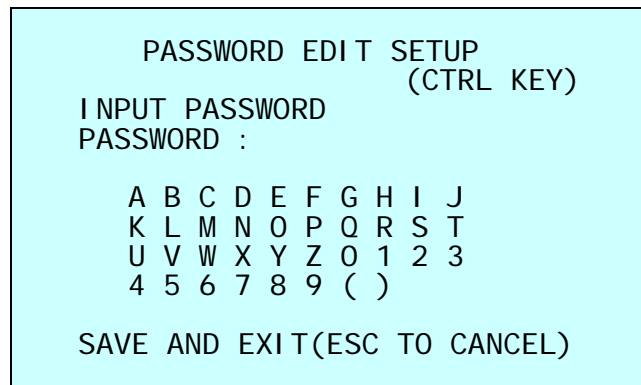

You can change the password with 6-digit character in this menu.

The default password is **555555**.

When the password enable is on, the input password window displays to enter the menu. At this time, move the cursor to the desired character by the **Joystick** and press the **CTRL** or **IRIS Open** key.

ORIGIN CHECK

When you find the wrong position of the dome during operation, execute this origin check and the dome camera will arrange the right position after the origin check operation.

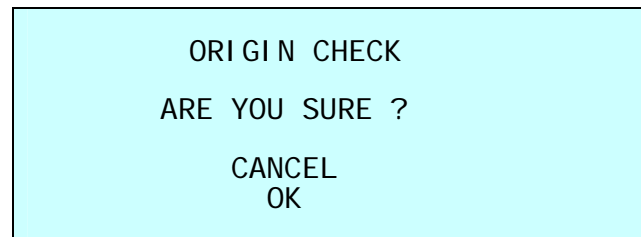

Pressing **151** + **ON** keys will execute the origin check.

• SYSTEM INFORMATION

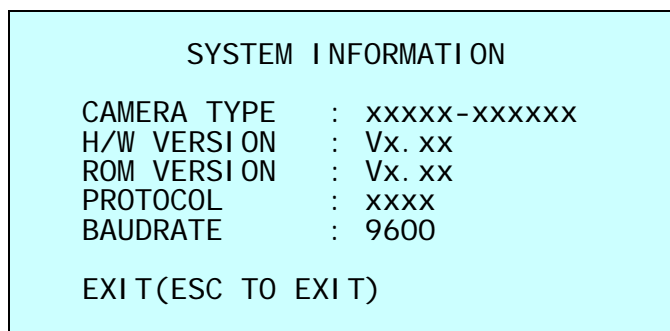

The system information provides essential information about the dome camera if service is required. When you view this screen, you can determine the camera type, ROM version. The information on this screen cannot be modified.

3.14 Function Run

This Function Run menu allows you to execute the function when you use a keyboard or a DVR without the function keys (Preset, Pattern, Tour and Scan).

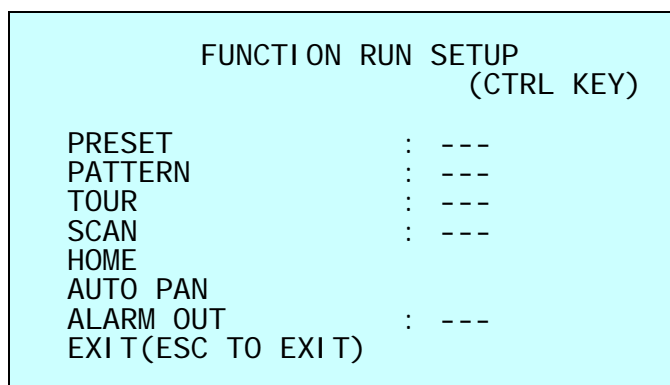

1. Select the desired Function by pushing the **Joystick** up or down.
2. Select the number by twist the **Joystick** in PRESET, PATTERN, TOUR, and SCAN.
3. Press the **CTRL** or **IRIS Open** key to execute.

NOTE: To execute the function, you should save the function (PRESET, PATTERN, TOUR, and SCAN) first.

- HOME

Select "HOME" and press the **CTRL** key. Then dome camera goes to the default position to which the dome camera returns after an assigned period of inactivity passes. The default position may be a Preset, Tour, Pattern or no action.

- AUTO PAN

You can execute the endless auto pan which is to turn one direction continuously by select the Auto Pan.

- ALARM OUT

This function can operate only when the alarm out setup has the time in the alarm menu.

Ex)

```
ALARM OUT SETUP
OUT      : 1 MIN
EXIT(ESC TO EXIT)
```

You press the **CTRL** or **IRIS Open** key then that alarm out operates during the setting time only.

3.15 Factory Setup

```
FACTORY SETUP
TOUR DWELL TIME : 03 SEC
ANSWER DELAY    : 03 SEC
SAVE AND EXIT(ESC TO CANCEL)
```

Pressing **250** + **PRST** keys pops up this menu.

TOUR DWELL TIME means the dwell time between Tours.

ANSWER DELAY means the response time of the dome and you don't need to change in normal condition.

Appendix A — Specifications

22X Optical Zoom PTZ III Dome System

MODEL	22X
MODULE	
CCD Type	1/4" Type EXview HAD CCD
Optical / Digital Zoom	22X / 16X
Resolution	580 TVL
Focal length	f = 3.9mm ~ 85.8mm
Angle of view	3.9mm – 49.5° (H) 85.8mm – 2.4° (H)
F-Number	F1.6 – F3.7
Min. Illumination	
- Normal	0.5 Lux
- Low Shutter	0.01 Lux
- ICR on & Low Shutter	0.001 Lux
ICR on (Day & Night)	YES
WDR	YES
Motion Detection (in PRESET)	YES
DOME	
Tilt angle	0° ~ 180° (Digital Flip)
Image Flip	YES
Auto Calibration	0.1° ~ 6°
Panning angle	360 continuous rotation
Alarm	1 input (NC/NO), 1 TTL output
Auto Scan	1 auto pan & 4 auto scan capability
Preset	120 presets with individual camera AE setup
Pattern	4 patterns (recording up to 200 sec.)
Tour	4 tours (consist of 42 functions / 1 tour)
Max Speed	380° /sec.
Area Title	it can be divided 8 areas with 12 characters of title
Privacy Zone	4 privacy zone masking (2 methods selectable : Block / video off)
Electrical	
Power Source	12V DC / 24V AC ± 10% for Dome 24V AC ± 10% for Heater & Fan
Power Consumption	12W for Dome 45W for Heater & Fan
Control	RS-485, baud rate: 2400~19.2k bps (default: 9600 bps)
ID (Camera Address)	1 ~ 255
Mechanical	
Dimension	See dimension
Weight	Approx. 2.2 kg for dome
Environment	
Operating temperature	-30°C to 50°C (-22°F to 122°F)
Operating humidity	0 to 90%RH (non-condensing)
Storage temperature	-20°C to 60°C (-4°F to 140°F)

* Specifications are subject to change without notice *

UNIT : mm

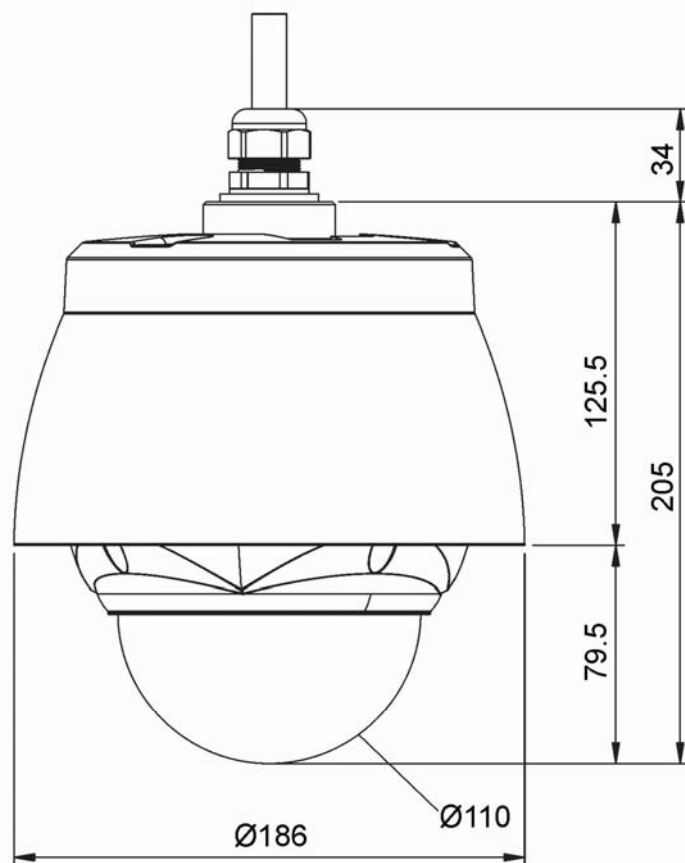
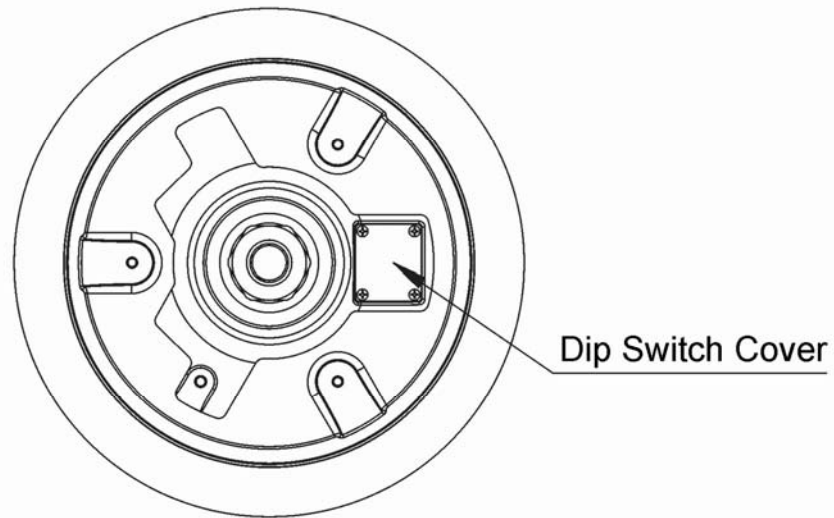

Figure 6 – Dimension

Appendix B — Troubleshooting

If problems occur, verify the installation of the camera with the instructions in this manual and with other operating equipment. Isolate the problem to the specific piece of equipment in the system and refer to the equipment manual for further information.

Problem	Possible Solution
No video.	Verify that power is connected to all pieces of equipment in the system. Verify that the power switches are in the ON position. Check the video connections.
Poor video quality.	Check that the BNC connectors are inserted properly. Check the voltage level of the dome camera. Cable for video is shielded.
Dome cameras lose their positions.	Reset the cameras using the Dome configuration menus. Check that the dome cameras are inserted properly in the base. Check the voltage level of the dome camera.
Camera number does not match the multiplexer number.	Check the camera ID and insert the BNC cable into the proper input of the multiplexer.
Picture is torn when switching	Check Line Lock setting and adjust phase of L/L

Appendix C — Glossary

Alarm Action

The assigned responses for the dome camera when input change from normal to abnormal states. The dome may run a Preset, Pattern, or have no assigned action for 1 dome input. The dome may also send alarm state to the host controller for processing. See also Input Alarm and Normal Input State.

Area

Programmed start and end points of the dome's field of view around its pan axis. Each area is a part of a circular viewing area that extends around the dome. The areas can be different sizes. Up to 8 areas can be programmed for the dome.

Automatic Gain Control (AGC)

Allows for the amplification of the video signal in scenes with minimal ambient light. Many low-light scenes result in picture noise. As gain is increased, the picture noise is also amplified. When AGC is enabled, the value of the gain setting is based on feedback from the camera. When AGC is disabled, the camera uses the value set for the manual gain setting. The trade-off between picture level and noise may be adjusted when AGC is disabled.

On-screen Menu

The text overlay menu system used for setting dome features. The utility is accessed using a keystroke combination. The utility provides settings for camera functions, zoom, alarm, text display, and password protection.

Flip

Allows the dome to automatically turn 180 degrees when the camera tilts to its lower limit and stays in that position for a brief delay. When the dome flips (rotates), the camera starts moving upward as long as the tilt control is kept in the down position. Once the control is released, the tilt control returns to its normal operational mode. The flip feature is useful when you need to track someone who walks directly beneath the dome and continues on the other side.

Home Position

The default position to which the dome camera returns after an assigned period of inactivity passes. The default position may be a Preset, Tour, Pattern, or No Action.

Input Alarm

A connection point on the dome camera that enables the system to monitor Input Devices. There are 1 input available for the dome camera.

Input Device

External devices that provide information about the condition of system components that connect to the input on the dome camera. Typical input devices include door contacts, motion detectors and smoke detectors.

IR Mode

A feature of the camera that permits manual or automatic switching between color and IR (black-and-white) operation. When IR mode is active, clearer images may be obtained under low-light conditions.

Line Lock

Allows you to phase lock the video with the AC power line. When line lock is enabled, it prevents vertical video rolling when switching multiple cameras to a single monitor. If text appears slightly tinted on color monitors, disabling the line lock may prevent this problem.

Name Information

Relates to the display the dome name, the area where the dome is pointing, the name of the Preset or Pattern that is running, and alarm name. The display of each type of name setting can be enabled or disabled. When the display of camera or area title(name) is enabled, the information appears on the screen continuously. Preset, Tour and Pattern titles(names) appear only while they are active.

Normal Input State

Describes the expected state of a device connected to dome camera's input. The normal state may be open or closed. When a device is not in its normal input state, an alarm is issued.

North Position

User-definable setting that may correspond to magnetic north or some well-known landmark. Used to approximate the camera dome's pointing direction when Direction Indicators are enabled.

Slow Shutter

Setting used to improve the quality of video obtained in extreme low-light situations. When the Low Shutter setting is enabled, low-light information is collected over multiple fields based on the Shutter Limit setting. As a result, video may appear blurred or choppy in extreme low-light situations. This setting does not effect camera operation in normal lighting situations.

Pattern

A series of pan, tilt, zoom and focus movements from a single programmable dome. Up to 4 Patterns may be programmed for the dome camera.

Preset

Programmed video scene, based on a specific pan, tilt, zoom, and focus settings. Up to 120 Presets may be programmed for the dome camera.

Privacy Zone

Masked areas of the dome camera's viewing area. These masks prevent operators of the surveillance system from viewing these designated zones. The Privacy Zones move in relation to the dome camera's pan/tilt position. In addition, the apparent size of the Privacy Zone adjusts automatically as the lens zooms in or out. Up to 4 Privacy Zones may be established for a dome camera.

Vector Scan

Move from start point to end point including tilt and zoom simultaneously and linearly.

White balance

Adjustments in the color hue(red and blue) gains for a camera so that true white appears white in the image. It is normally compensated for by the automatic gain control. In some lighting conditions, you may need to manually adjust the red and blue settings for optimal viewing. When Automatic White Balance is enabled, the camera measures the image and automatically adjusts the red and blue settings to balance white. When Automatic White Balance is disabled, the camera uses the values set for the red and blue settings to balance white.

Appendix D — Short Cut Key

Short Cut Key		Function	
PRST		Pop up Preset setup menu.	
TOUR		Pop up Tour setup menu.	
PTRN		Pop up Pattern setup menu.	
SCAN		Pop up Auto Scan setup menu.	
No.+ CTRL+ PRST		Store the current view at the selected number.	
Short Cut Key	Function	Short Cut Key	Function
7+ ON	Change FOCUS to AUTO	7+ OFF	Change FOCUS to manual
8+ ON	Change AE to AE1	8+ OFF	Change AE to manual
9+ ON	Change Night Shot to AUTO		
10+ ON	Night Shot on (go to the manual mode)	10+ OFF	Night Shot off (go to the manual mode)
11+ ON	BLC on (AE auto1 mode)	11+ OFF	BLC off (AE auto1 mode)
12+ ON	Digital Zoom on (According to digital zoom setting)	12+ OFF	Digital Zoom off
13+ ON	Dome OSD on	13+ OFF	Dome OSD off
14+ ON	Dome Area Title Display on	14+ OFF	Dome Area Title Display off
15+ ON	View Direction on	15+ OFF	View Direction off
104+ ON	WDR ON	104+ OFF	WDR off
150+ ON	Image Flip ON	150+ OFF	Image Flip off
151+ ON	Origin Check		
152+ ON	Place the camera in the 0° area horizontally.		
153+ ON	Go to the slow speed mode	153+ OFF	Go to the normal speed mode
154+ ON	Display System Information		
155+ ON	Flip the camera in the 180° area horizontally.		
250+ PRST	Factory setup menu (Tour dwell time, Answer delay)		
888+ ENTER	Night Shot on (in the global mode only)		
999+ ENTER	Night Shot off (in the global mode only)		

Appendix E — Wall Mount

The wall mounting plate must be attached to a structural object such as concrete that will support the weight of the mount and Dome Camera.

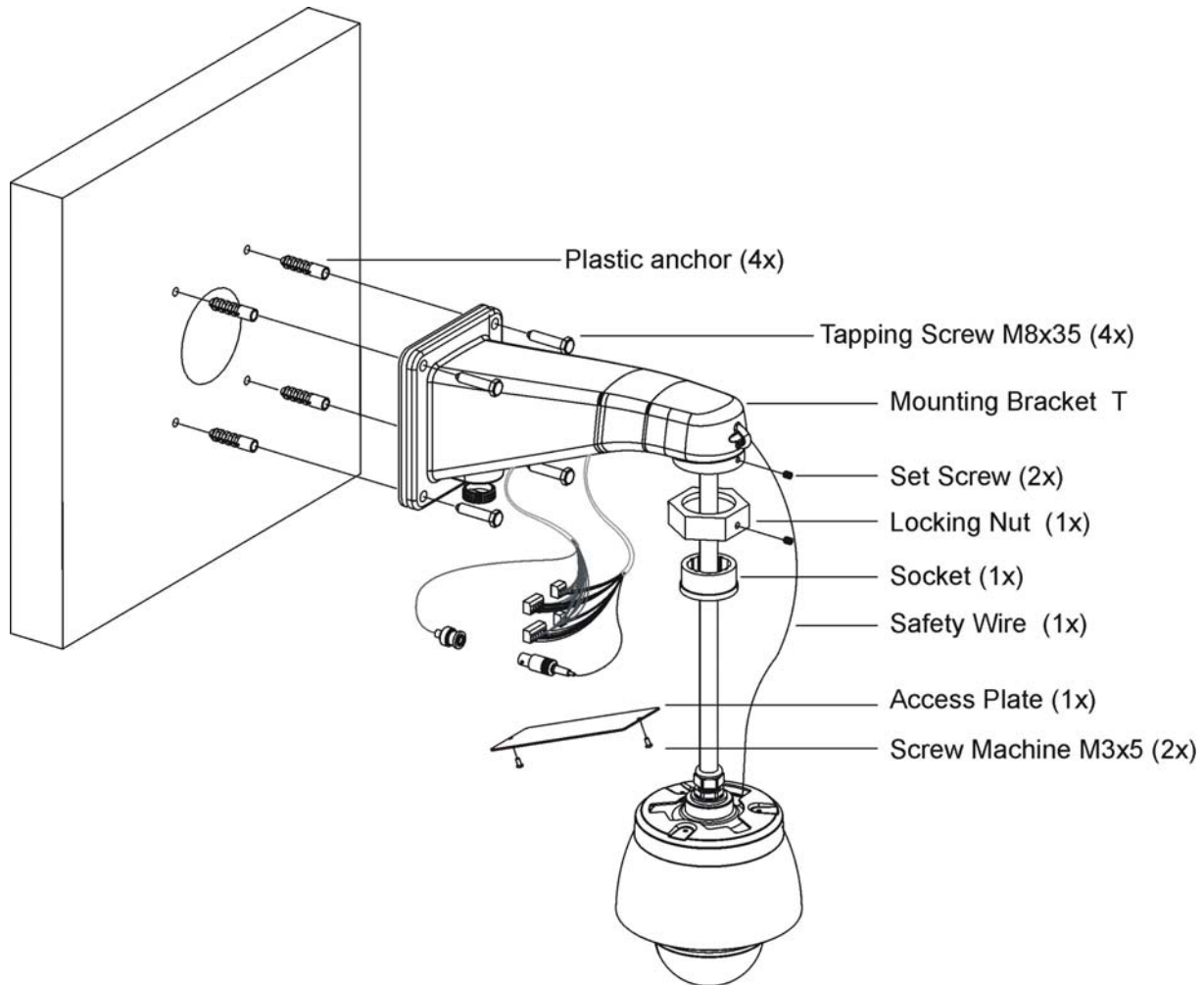

1. Select a suitable mounting location and verify there is sufficient cable to reach the middle of the Wall Mount.
2. Mark and drill mounting holes in the surface using the Wall Mount Flange.
3. Pull out cables required to connect to the dome camera from the wall or route cables through a section of 0.75 in. (19 mm) conduit pipe.
4. Remove the access plate from the wall mount bracket.
5. Attach the wall mount bracket using screws routing cables through the access plate's hole.
6. Attach the housing's safety wire to the wall mount's latch.
7. Fix the housing to the wall mount bracket using the locking nut after routing cables through the wall mount bracket and tighten the housing set screw with the supplied wrench.
8. After connecting cables, attach the access plate.

Appendix F — Ceiling Mount

The ceiling mounting plate must be attached to a structural object such as concrete that will support the weight of the mount and Dome Camera.

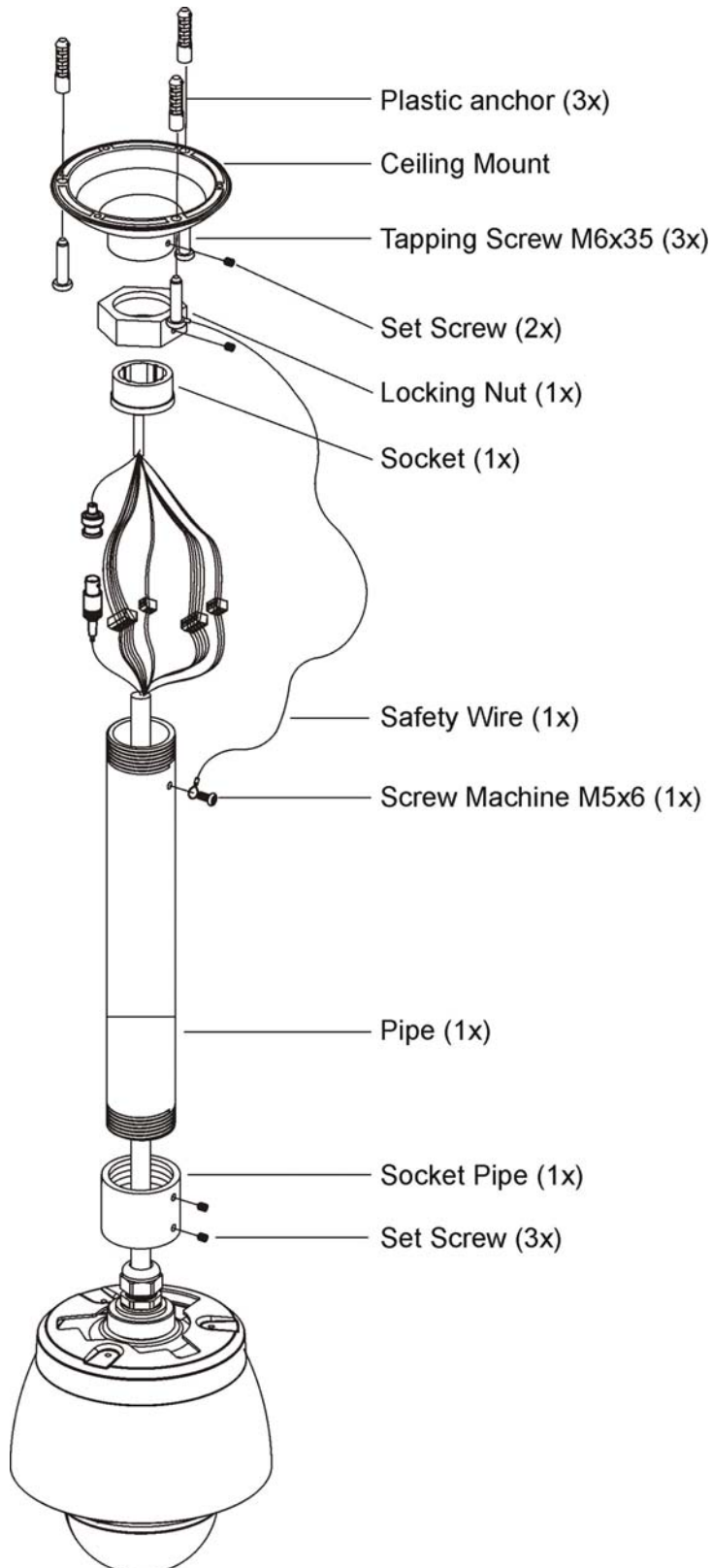

1. Select a suitable mounting location and verify there is sufficient cable to connect with cables from the housing.
2. Mark and drill mounting holes in the surface using the ceiling mount flange.
3. Pull out cables required to connect to the dome camera from the ceiling.
4. Attach the ceiling mount bracket using screws routing cables through the locking nut.
5. Tighten the housing with the pipe using the socket after routing cables through the pipe.
6. Attach the housing's safety wire to the ceiling mount's m6X35 tapping screw.
7. After connecting cables, fix the pipe to the ceiling mount using the locking nut.
8. Tighten set screws of the socket and locking nut with the supplied wrench.



22X PTZ III DOME CAMERA
