

600TV Lines Super High Resolution Color Camera



1/3" INTERLINE TRANSFER CCD
HIGH RESOLUTION

*Please read this manual thoroughly before use, and keep it handy for future reference.
Design and specifications are subject to change without notice.*

WARNINGS AND CAUTIONS:

TO REDUCE THE RISK OF FIRE OR ELECTRIC SHOCK, DO NOT EXPOSE THIS PRODUCT TO RAIN OR MOISTURE. DO NOT INSERT ANY METALLIC OBJECTS THROUGH THE VENTILATION GRILLS OR OTHER OPENINGS ON THE EQUIPMENT.

CAUTION:

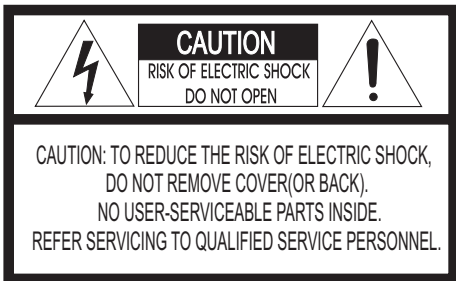

EXPLANATION OF GRAPHICAL SYMBOLS



The lightning flash with arrowhead symbol, within an equilateral triangle, is intended to alert the user to the presence of uninsulated "dangerous voltage" within the product's enclosure that may be of sufficient magnitude to constitute a risk of electric shock to persons.



The exclamation point within an equilateral triangle is intended to alert the user to the presence of important operating and maintenance (servicing) instructions in the literature accompanying the product.

PRECAUTIONS

Safety -----

Should any liquid or solid object fall into the cabinet, unplug the unit and have it checked by the qualified personnel before operating it any further.

Unplug the unit from the wall outlet if it is not going to be used for several days or more. To disconnect the cord, pull it out by the plug. Never pull the cord itself.

Allow adequate air circulation to prevent internal heat build-up. Do not place the unit on surfaces (rugs, blankets, etc.) or near materials (curtains, draperies) that may block the ventilation holes.

Height and vertical linearity controls located at the rear panel are for special adjustments by qualified personnel only.

Installation -----

Do not install the unit in an extremely hot or humid place or in a place subject to excessive dust, mechanical vibration.

Cleaning -----

Clean the unit with a slightly damp soft cloth. Use a mild household detergent. Never use strong solvents such as thinner or benzene as they might damage the finish of the unit.

Retain the original carton and packing materials for safe transport of this unit in the future.

FCC COMPLIANCE STATEMENT

FCC INFORMATION : THIS EQUIPMENT HAS BEEN TESTED AND FOUND TO COMPLY WITH THE LIMITS FOR A CLASS A DIGITAL DEVICE, PURSUANT TO PART 15 OF THE FCC RULES. THESE LIMITS ARE DESIGNED TO PROVIDE REASONABLE PROTECTION AGAINST HARMFUL INTERFERENCE WHEN THE EQUIPMENT IS OPERATED IN A COMMERCIAL ENVIRONMENT. THIS EQUIPMENT GENERATES, USES, AND CAN RADIATE RADIO FREQUENCY ENERGY AND IF NOT INSTALLED AND USED IN ACCORDANCE WITH THE INSTRUCTION MANUAL, MAY CAUSE HARMFUL INTERFERENCE TO RADIO COMMUNICATIONS. OPERATION OF THIS EQUIPMENT IN A RESIDENTIAL AREA IS LIKELY TO CAUSE HARMFUL INTERFERENCE IN WHICH CASE THE USER WILL BE REQUIRED TO CORRECT THE INTERFERENCE AT HIS OWN EXPENSE.

CAUTION : CHANGES OR MODIFICATIONS NOT EXPRESSLY APPROVED BY THE PARTY RESPONSIBLE FOR COMPLIANCE COULD VOID THE USER'S AUTHORITY TO OPERATE THE EQUIPMENT.

THIS CLASS A DIGITAL APPARATUS COMPLIES WITH CANADIAN ICES-003.

CET APPAREIL NUMÉRIQUE DE LA CLASSE A EST CONFORME À LA NORME NMB-003 DU CANADA.

CE COMPLIANCE STATEMENT

WARNING

THIS IS A CLASS A PRODUCT. IN A DOMESTIC ENVIRONMENT THIS PRODUCT MAY CAUSE RADIO INTERFERENCE IN WHICH CASE THE USER MAY BE REQUIRED TO TAKE ADEQUATE MEASURES.

IMPORTANT SAFEGUARDS

1. Read these instructions.
 2. Keep these instructions.
 3. Heed all warnings.
 - 4 . Follow all instructions.
 5. Do not use this apparatus near water.
 6. Clean only with dry cloth.
 7. Do not block any ventilation openings. Install in accordance with the manufacturer's instructions.
 8. Do not install near any heat sources such as radiators, heat registers, stoves, or other apparatus (including amplifiers) that produce heat.
 9. Do not defeat the safety purpose of the polarized or grounding-type plug. A polarized plug has two blades with one wider than the other. A grounding type plug has two blades and a third grounding prong. The wide blade or the third prong are provided for your safety. If the provided plug does not fit into your outlet, consult an electrician for replacement of the obsolete outlet.
 10. Protect the power cord from being walked on or pinched particularly at plugs, convenience receptacles, and the point where they exit from the apparatus.
 11. Only use attachments/accessories specified by the manufacturer.
 12. Use only with the cart, stand, tripod, bracket, or table specified by the manufacturer, or sold with the apparatus.
When a cart is used, use caution when moving the cart/apparatus combination to avoid injury from tip-over.
- 
13. Unplug this apparatus during lightning storms or when unused for long periods of time.
 14. Refer all servicing to qualified service personnel. Servicing is required when the apparatus has been damaged in any way, such as power-supply cord or plug is damaged, liquid has been moisture, does not operate normally, or has been dropped.
 15. **CAUTION THESE SERVICING INSTRUCTIONS ARE FOR USE BY QUALIFIED SERVICE PERSONNEL ONLY. TO REDUCE THE RISK OF ELECTRIC SHOCK DO NOT PERFORM ANY SERVICING OTHER THAN THAT CONTAINED IN THE OPERATING INSTRUCTIONS UNLESS YOU QRE QUALIFIED TO DO SO.**
 16. **Use satisfy clause 2.5 of IEC60950-1/UL60950-1 or Certified/Listed Class 2 power source only.**

INTRODUCTION

The camera provides high-quality images using Sony CCD technology especially designed for closed-circuit television (CCTV) and security surveillance applications.

Features:

- High resolution and high performance 1/3" Sony® Super HAD™ II Technology
- Excellent picture quality
- 600 lines(Color) of resolution
- 0.1 lux(Color), 0.04lux(B/W) @ F1.2 50IRE Sensitivity
- Auto electronic shutter [1/60(1/50) ~ 1/100,000] and manual electronic shutter modes
- OSD (On Screen Display)
- Auto and manual white balance modes
- DWDR
- OSD Font Color (16 Color)
- BLC (Back Light Compensation)
- Day&Night (Auto / DAY / NIGHT / EXT)
- Private Mask (8 position, 16 Colors)
- AGC (Auto Gain Control)
- MIRROR (ON/OFF)
- VIDEO OUT BNC
- Motion Detection(4 point)
- HLC (High Light Compensation)
- DPC (Dead Pixel Cancellation)
- Operates in AC24V +/- 10% / DC12V +/- 10%
- Use Certified / Listed Class 2 power source only



IMPORTANT : The user of this camera is responsible for checking and complying with local, state, and federal laws and statutes concerning the recording and monitoring of audio signals.

CAMERA OVERVIEW

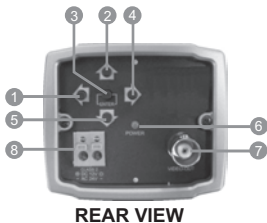
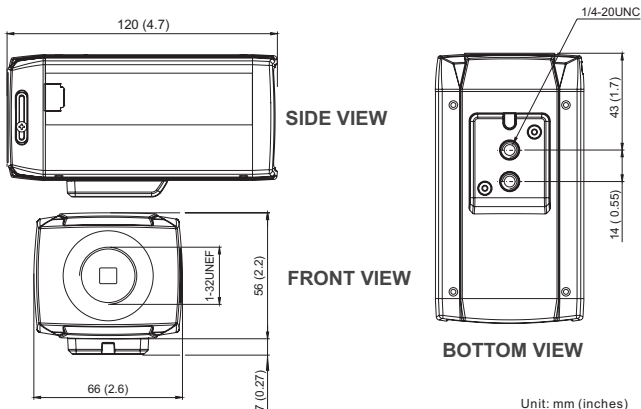

- 1 Left Button
- 2 Up Button
- 3 Enter Button
- 4 Right Button
- 5 Down Button
- 6 Power Indicator
- 7 Video Out Connector (BNC)
- 8 AC/DC Compatible Input Terminal

CONTENTS OF PACKAGE

Installation of the camera must be performed by qualified service personnel in accordance with all local and national electrical and mechanical codes.

Carefully remove the color camera and its accessories from the carton and verify that they were not damaged in shipment.

The contents of the package includes:

1. Color CCD camera
2. Mini-DIN connector (for video-or dc-type auto-iris lens)
3. CS adapter ring for C mounting "C" lensesal

STRUCTURE OF THE SETUP MENU

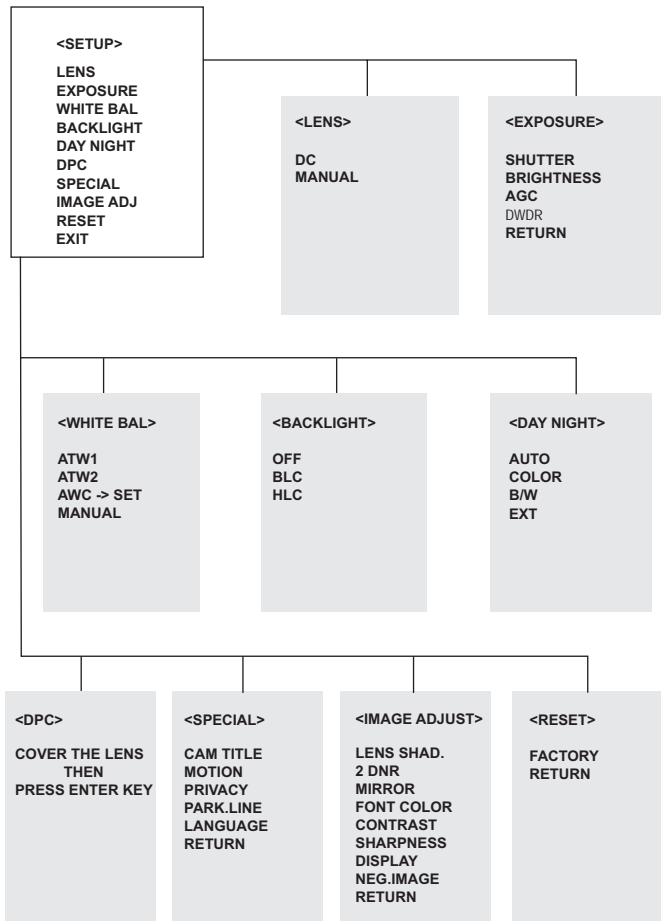

LENS (Selection)

This function is used to adjust the brightness of the screen.

1. When the SETUP menu is displayed on the screen, please position the arrow to point to 'LENS' by using the UP and DOWN buttons.
2. Please select the type of the lens you wish to use by pressing the LEFT or RIGHT button.

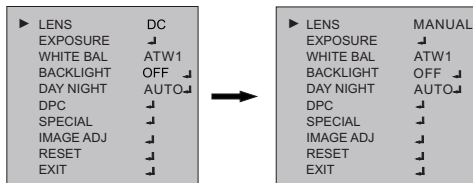

Note The brightness of the screen can be adjusted in DC mode.

EXPOSURE

The EXPOSURE menu is used to set the automatic light control method for this camera.

- 1) **SHUTTER** Select the shutter mode.(Auto, 1/60(50), FLK~ 1/100,000 sec)
Can be changed while in shutter mode.
- 2) **BRIGHTNESS** Adjust BRIGHTNESS level (0 ~ 255)
Can be adjusted while in DC/ manual lens mode.
- 3) **AGC** Auto gain control (OFF / LOW / MIDDLE / HIGH)
- 4) **DWDR** Digital Wide dynamic range(Xtended Dynamic Range)
OFF / ON

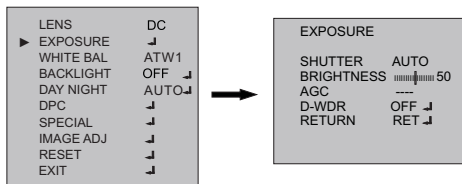

WHITE BAL

The screen color can be adjusted by using the WHITE BALANCE function.

- 1) **ATW1** Set the color temperature 2500°K 10000°K
- 2) **ATW2** Set the color temperature 2000°K 13000°K
- 3) **AWC -> SET** Please press the ENTER button while the camera is directed at a piece of white paper to obtain the optimum state under current illumination. if the environment including the light source is changed, you have to adjust the white balance again.
- 4) **MANUAL** Manual mode. User can change R and B Gain manually.
 - INDOOR Set the color temperature to 3200°K
 - OUTDOOR Set the color temperature to 6300°K

<WHITE BAL MANUAL MODE>

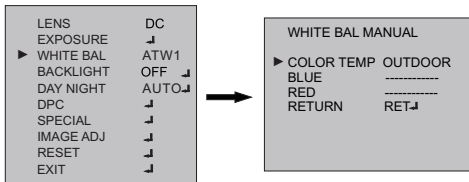

BACKLIGHT

- 1) **BLC** Prevents such a back light effect to secure a clear image under all illumination environments
- 2) **HLC** The function improves the identification capability of subjects facing a brightly lit situation by filtering out the strength of the light

<BACKLIGHT MODE>

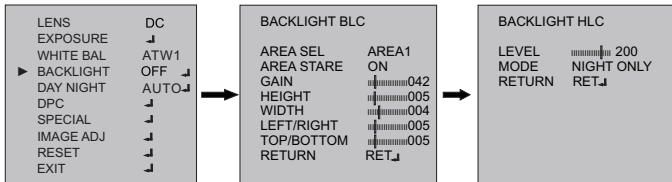

DAY NIGHT

The DAY/NIGHT menu is used to configure the day and night related setting for this camera. This camera can turn the IR(infrared)filter on or off.

Mode : AUTO / COLOR / B/W / EXT (The EXT is not operating in this mode)

<DAY NIGHT AUTO MODE>

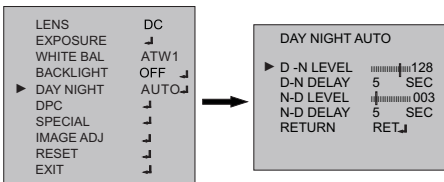

<DAY NIGHT B/W MODE>

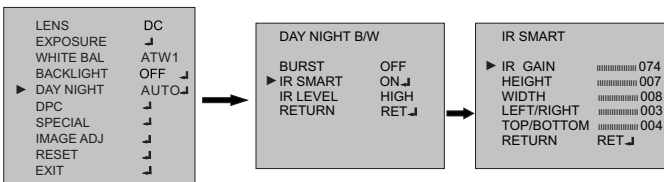

*The IR LEVEL is not operating in DAY NIGHT B/W mode.

DPC

DPC Auto setting (Dead pixels are automatically removed)

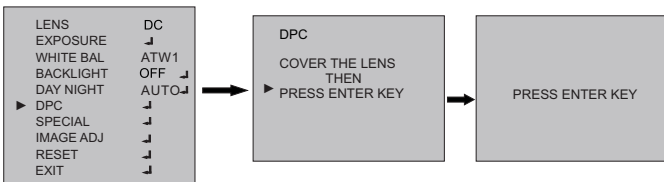

SPECIAL

1) CAM TITLE

A ——— **CAM TITLE**
 0123456789
 ABCDEFGHIJK
 LMNOPQRSTU
B ——— WXYZ ▶→←↑↓()
 ~_#/= & : ~. . ↓
C ——— ↔ CLR POS END

A. CAM TITLE

B. Character Table

C. Command Line

← : Move to left

→ : Move to right

CLR : Erase all characters

POS : Move the position of title

END : Save and End

2) MOTION

AREA SELECT

Select MD area number. (AREA1 ~AREA4)

AREA STATE

Select MD ON/OFF

HEIGHT

Adjust height of MD area

WIDTH

Adjust width of MD area

LEFT/RIGHT

Adjust the location of the MD area with boundary LEFT and RIGHT.

TOP/BOTTOM

Adjust the location of the MD area with boundary TOP and BOTTOM

DEGREE

Adjust sensitivity of MD area.(0~255)

VIEW

The screen displays with pink dots. When a motion is detected in the selected area, the pink dots are displayed on the screen.

| | |
|-----------|--------|
| LENS | DC |
| EXPOSURE | ↓ |
| WHITE BAL | ATW1 |
| BACKLIGHT | OFF ↓ |
| DAY NIGHT | AUTO ↓ |
| DPC | ↓ |
| ▶ SPECIAL | ↓ |
| IMAGE ADJ | ↓ |
| RESET | ↓ |
| EXIT | ↓ |

| | |
|-------------|---------|
| SPECIAL | |
| ▶ CAM TITLE | ON ↓ |
| ▶ MOTION | ON ↓ |
| PRIVACY | OFF |
| PARK.LINE | OFF |
| LANGUAGE | ENGLISH |
| RETURN | RET ↓ |

| | |
|---------------|-------|
| MOTION | |
| ▶ AREA SELECT | AREA1 |
| AREA STATE | ON |
| HEIGHT | 4 |
| WIDTH | 4 |
| LEFT/RIGHT | 2 |
| TOP/BOTTOM | 2 |
| DEGREE | 38 |
| VIEW | OFF |
| RETRURN | RET ↓ |

3) PRIVACY

- AREA SELECT** Select MASK area number.(Area 1 ~ Area 8)
- AREA STATE** Select MASK ON/OFF
- HEIGHT** Adjust height of MASK area
- WIDTH** Adjust width of MASK area
- LEFT/RIGHT** Adjust the location of the MASK area with boundary LEFT and RIGHT
- TOP/BOTTOM** Adjust the location of the MASK area with boundary TOP and BOTTOM.
- COLOR** Select MASK color. (0~15)
- RETURN**

<PRIVACY MODE>

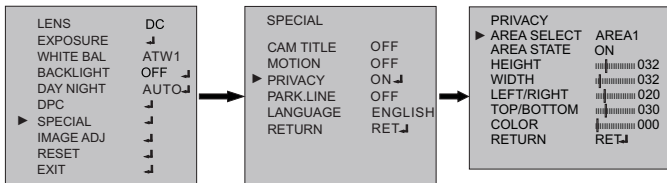

4) PARK.LINE

Select Parking area

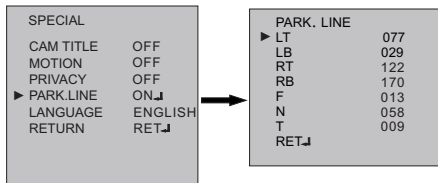

5) LANGUAGE

ENGLISH or CHINESE

6) RETURN

RET

IMAGE ADJUST

- 1) **LENS SHAD** Adjust Lens shading level (0~255)
- 2) **2DNR** Select 2DNR ON/OFF
- 3) **MIRROR** Select MIRROR ON/OFF
- 4) **FONT COLOR** Select FONT COLOR level (0~15)
Select IDR TITLE level (0~15)
- 5) **CONTRAST** Adjust CONTRAST level (0~255)
- 6) **SHARPNESS** Adjust SHARPNESS level (0~31)
- 7) **DISPLAY** Select DISPLAY mode (CRT /LCD/USER)
- 8) **NEG. IMAGE** Select Negative image mode ON /OFF

<IMAGE ADJUST MODE>

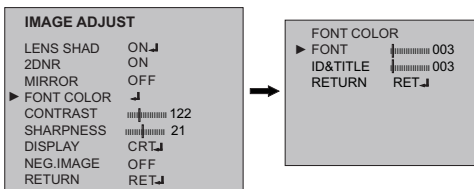
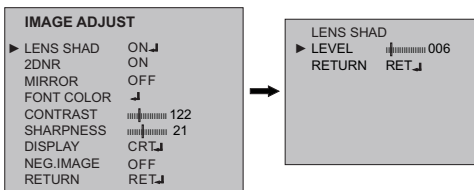

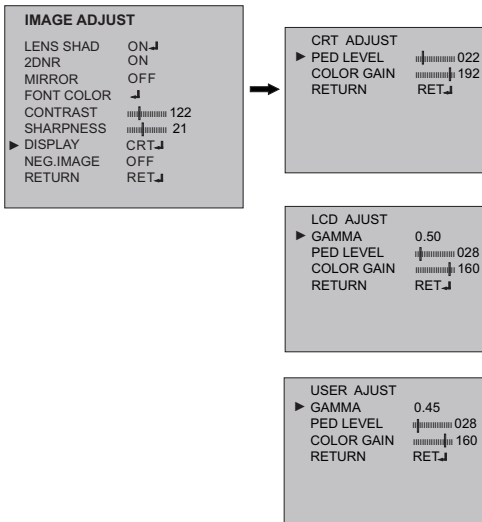

RESET

1) FACTORY

Returns to the level which was set by the manufacturer for shipment.

EXIT

1) EXIT

Saves all setting and exits.

CONTROL AND CONNECTIONS/DAY&NIGHT I/O / ALARM OUT TERMINALS

1) POWER INPUT TERMINAL



- This terminal accepts a DC12V or AC24V power source from a DC12V or AC24V ac +/-10% 60/50Hz +/- 1Hz.
- Use Certified/Listed Class 2 power source only.
- In DC power, use the Adapter mode than DC 12V 500mA Capacity.

2) VIDEO OUT CONNECTOR

BNC : This BNC connector provides a 1.0Vp-p/75 ohms composite video Signal.

LENS

The lens is not supplied with this camera. Purchase a lens suitable for your environment. This camera accepts the auto iris lens and both C-and CS-mount lens.

* Notes *

- For using main functions it is recommended to use Auto Iris Lens with DC type.
- If the lens is marked with fingerprints other marks, the image quality might be poor.
- It is recommended to use a high quality lens to improve the image quality under low illumination.

<INSTALLING AUTO IRIS LENS>

1. Remove the cover from the iris lens plug supplied, and solder the lens cable to the plug as shown below.

- Video type :
Pin 1 --- Red (Power source)
Pin 2 --- N.C
Pin 3 --- White (Video signal)
Pin 4 --- Black (GND)

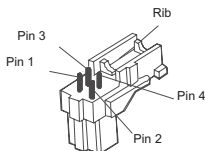

- DC type :
Pin 1 --- Damping-
Pin 2 --- Damping+
Pin 3 --- Drive+
Pin 4 --- Drive-

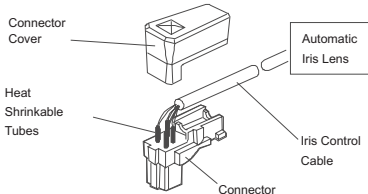

2. Remove the protective cap, and attach the lens to the camera by turning clockwise.

SPECIFICATIONS

| MODEL | | NTSC | PAL | |
|-----------------------|------------------------|---|--|--|
| Power | Power source | AC24V ± 10% / DC12V ± 10% | | |
| | Power consumption | 200mA (2.5 Watts) | | |
| General | Image sensor | 1/3" Sony Super HAD CCD II | | |
| | Total pixels | 811(H) x 507(V) | 795(H) x 595(V) | |
| | Scanning system | 2:1 interlace | | |
| | Scanning frequency | 15.734KHz(H) x 59.94Hz(V) | 15.625KHz(H) x 50Hz(V) | |
| | Sync. system | Internal | | |
| | Electronic Shutter | 1/60 ~ 1/100,000 sec. | 1/50 ~ 1/100,000 sec. | |
| | Resolution | 600 TV lines (Color) | | |
| | Min. illumination | 0.1 Lux(Color), 0.04 Lux(B/W) @ F1.2, 50IRE | | |
| | Video Output | 1.0 Vp-p (75 ohm, Composite) | | |
| | S/N Ratio | More than 50dB (AGC off) | | |
| Camera Control | OSD (Tact Switch) | | | |
| FUNCTION OPTION | Lens | MANUAL / DC | | |
| | Shutter | AUTO, 1/60(1/50), Flickerless, 1/250 ~ 1/100,000sec | | |
| | Brightness | 0 ~ 255 | | |
| | Backlight | OFF / BLC / HLC(High Light Compensation) | | |
| | AGC | OFF / LOW / MIDDLE / HIGH | | |
| | DWDR | OFF/ON | | |
| | White Balance | ATW1 / ATW2 / AWC->SET / MANUAL | | |
| | Day & Night | AUTO / COLOR / B&W / EXT | | |
| | D&N B/W | Burst | OFF / ON | |
| | | IR Smart | OFF / ON | |
| | | IR Level | LOW / HIGH | |
| | SPEC IAL | Camera Title | OFF / ON | |
| | | Motion Detection | OFF / ON (4 area) | |
| | | Privacy Masking | OFF / ON (8 position) | |
| | | Parking Line | OFF / ON | |
| | | Lens Shading | OFF / ON (0~255) | |
| | | 2DNR | OFF / ON | |
| | | Mirror | OFF / ON | |
| | | Font Color | FONT 16 COLOR, ID&TITLE 16 COLOR | |
| | | Contrast | 0~255 | |
| | | Sharpness | 0~31 | |
| | | Display | CRT / LCD / USER | |
| | | Nega Image | OFF / ON | |
| | | Language | ENGLISH / CHINESE | |
| | | DPC | Dead Pixel Cancellation (Auto 64 Points) | |
| | Reset | FACTORY RESET / RETURN | | |
| | Connector & etc. | Power input | 2-pin terminal block | |
| Video output | | BNC connector | | |
| Auto iris output | | 4-Pin Mini Din jack (standard connection) | | |
| Lens Mount | | C/CS Mount (Selected through back focus) | | |
| Mounting Hole | | 1/4"-20 UNC (top or bottom) | | |
| Operating temperature | | 14°F ~ 122°F (-10°C ~ +50°C) | | |
| Operating humidity | | 0 ~ 96% (non-condensing) | | |
| External Dimension | | 66(W) x 63(H) x 120(D) mm | | |
| Weight | 400g | | | |

MEMO
