



A-ADRP4E-120
A-ADRP9E-240
A-ADRP16E-320

Digital Video Recorders

| | | |
|--|---|---|
|  | WARNING RISK OF ELECTRIC SHOCK DO NOT OPEN |  |
| WARNING: TO REDUCE THE RISK OF ELECTRIC SHOCK, DO NOT REMOVE COVER (OR BACK). NO USER-SERVICEABLE PARTS INSIDE. REFER SERVICING TO QUALIFIED SERVICE PERSONNEL. | | |



The lightning flash with arrowhead symbol, within an equilateral triangle, is intended to alert the user to the presence of uninsulated "dangerous voltage" within the product's enclosure that may be of sufficient magnitude to constitute a risk of electric shock.



The exclamation point within an equilateral triangle is intended to alert the user to the presence of important operating and maintenance (servicing) instructions in the literature accompanying the appliance.

COMPLIANCE NOTICE OF FCC:

THIS EQUIPMENT HAS BEEN TESTED AND FOUND TO COMPLY WITH THE LIMITS FOR A CLASS A DIGITAL DEVICE, PURSUANT TO PART 15 OF THE FCC RULES. THESE LIMITS ARE DESIGNED TO PROVIDE REASONABLE PROTECTION AGAINST HARMFUL INTERFERENCE WHEN THE EQUIPMENT IS OPERATED IN A COMMERCIAL ENVIRONMENT. THIS EQUIPMENT GENERATES, USES, AND CAN RADIATE RADIO FREQUENCY ENERGY AND IF NOT INSTALLED AND USED IN ACCORDANCE WITH THE INSTRUCTION MANUAL, MAY CAUSE HARMFUL INTERFERENCE TO RADIO COMMUNICATIONS. OPERATION OF THIS EQUIPMENT IN A RESIDENTIAL AREA IS LIKELY TO CAUSE HARMFUL INTERFERENCE, IN WHICH CASE USERS WILL BE REQUIRED TO CORRECT THE INTERFERENCE AT THEIR OWN EXPENSE.

CAUTION: CHANGES OR MODIFICATIONS NOT EXPRESSLY APPROVED BY THE PARTY RESPONSIBLE FOR COMPLIANCE COULD VOID THE USER'S AUTHORITY TO OPERATE THE EQUIPMENT.

THIS CLASS OF DIGITAL APPARATUS MEETS ALL REQUIREMENTS OF THE CANADIAN INTERFERENCE-CAUSING EQUIPMENT REGULATIONS

THE INTERNAL MODEM OF THIS EQUIPMENT COMPLIES WITH PART 68 OF THE FCC RULES. ON THE BOTTOM OF THIS EQUIPMENT IS A LABEL THAT CONTAINS, AMONG OTHER INFORMATION, THE FCC REGISTRATION NUMBER, RINGER EQUIVALENCE NUMBER (REN), AND USOC JACK TYPE FOR THIS EQUIPMENT. YOU MUST, UPON REQUEST, PROVIDE THIS INFORMATION TO YOUR TELEPHONE COMPANY. THIS EQUIPMENT IS DESIGNED TO BE CONNECTED TO THE TELEPHONE NETWORK OR PREMISES WIRING USING A COMPATIBLE MODULAR JACK WHICH IS PART 68 COMPLIANT. THE REN IS USEFUL TO DETERMINE THE QUANTITY OF DEVICES YOU MAY CONNECT TO YOUR TELEPHONE LINE AND STILL HAVE ALL OF THOSE DEVICES RING WHEN YOUR TELEPHONE NUMBER IS CALLED. IN MOST, BUT NOT ALL AREAS, THE SUM OF THE REN'S OF ALL DEVICES CONNECTED TO ONE LINE SHOULD NOT EXCEED FIVE (5.0). TO BE CERTAIN OF THE NUMBER OF DEVICES YOU MAY CONNECT TO YOUR LINE, AS DETERMINED BY THE REN, YOU SHOULD CONTACT YOUR LOCAL TELEPHONE COMPANY TO DETERMINE THE MAXIMUM REN FOR YOUR CALLING AREA. IF YOUR TELEPHONE EQUIPMENT CAUSES HARM TO THE TELEPHONE NETWORK, THE TELEPHONE COMPANY MAY DISCONTINUE YOUR SERVICE TEMPORARILY. IF POSSIBLE, THEY WILL NOTIFY YOU IN ADVANCE, BUT IF ADVANCE NOTICE IS NOT PRACTICAL, YOU WILL BE NOTIFIED AS SOON AS POSSIBLE. YOU WILL BE INFORMED OF YOUR RIGHT TO FILE A COMPLAINT WITH THE FCC. YOUR TELEPHONE COMPANY MAY MAKE CHANGES IN ITS FACILITIES, EQUIPMENT, OPERATIONS OR PROCEDURES THAT COULD AFFECT THE PROPER FUNCTIONING OF YOUR EQUIPMENT. IF THEY DO, YOU WILL BE NOTIFIED IN ADVANCE TO GIVE YOU AN OPPORTUNITY TO MAINTAIN UNINTERRUPTED TELEPHONE SERVICE. IF YOU EXPERIENCE TROUBLE WITH THIS TELEPHONE EQUIPMENT, PLEASE CONTACT YOUR DEALER / INSTALLER FOR INFORMATION ON OBTAIN SERVICE OR REPAIRS. THE TELEPHONE COMPANY MAY ASK THAT YOU DISCONNECT THIS EQUIPMENT FROM THE NETWORK UNTIL THE PROBLEM HAS BEEN CORRECTED OR UNTIL YOU ARE SURE THAT THE EQUIPMENT IS NOT MALFUNCTIONING. THIS EQUIPMENT MAY NOT BE USED ON COIN SERVICE PROVIDED BY THE TELEPHONE COMPANY. CONNECTION TO PARTY LINES IS SUBJECT TO STATE TARIFFS.

NOTE: THE INTERNAL MODEM IS OPTIONALLY AVAILABLE FOR THE NETWORK-SUPPORTED PREMIUM MODEL.

The information in this manual is believed to be accurate as of the date of publication. ADT is not responsible for any problems resulting from the use thereof. The information contained herein is subject to change without notice. Revisions or new editions to this publication may be issued to incorporate such changes.

Important Safeguards

| | |
|--|---|
| <p>1. Read Instructions All the safety and operating instructions should be read before the appliance is operated.</p> <p>2. Retain Instructions The safety and operating instructions should be retained for future reference.</p> <p>3. Cleaning Unplug this equipment from the wall outlet before cleaning it. Do not use liquid aerosol cleaners. Use a damp soft cloth for cleaning.</p> <p>4. Attachments Never add any attachments and/or equipment without the approval of the manufacturer as such additions may result in the risk of fire, electric shock or other personal injury.</p> <p>5. Water and/or Moisture Do not use this equipment near water or in contact with water.</p> <p>6. Accessories Do not place this equipment on an unstable cart, stand or table. The equipment may fall, causing serious injury to a child or adult, and serious damage to the equipment. Wall or shelf mounting should follow the manufacturer's instructions, and should use a mounting kit approved by the manufacturer.</p> <div style="text-align: center;">  </div> <p>This equipment and cart combination should be moved with care. Quick stops, excessive force, and uneven surfaces may cause the equipment and cart combination to overturn.</p> <p>7. Power Sources This equipment should be operated only from the type of power source indicated on the marking label. If you are not sure of the type of power, please consult your equipment dealer or local power company.</p> <p>8. Power Cords Operator or installer must remove power and TNT connections before handling the equipment.</p> <p>9. Lightning For added protection for this equipment during a lightning storm, or when it is left unattended and unused for long periods of time, unplug it from the wall outlet and disconnect the antenna or cable system. This will prevent damage to the equipment due to lightning and power-line surges.</p> <p>10. Overloading Do not overload wall outlets and extension cords as this can result in the risk of fire or electric shock.</p> <p>11. Objects and Liquids Never push objects of any kind through openings of this equipment as they may touch dangerous voltage points or short out parts that could result in a fire or electric shock. Never spill liquid of any kind on the equipment.</p> <p>12. Servicing Do not attempt to service this equipment yourself. Refer all servicing to qualified service personnel.</p> | <p>13. Damage requiring Service Unplug this equipment from the wall outlet and refer servicing to qualified service personnel under the following conditions:</p> <p>A. When the power-supply cord or the plug has been damaged. B. If liquid is spilled, or objects have fallen into the equipment. C. If the equipment has been exposed to rain or water. D. If the equipment does not operate normally by following the operating instructions, adjust only those controls that are covered by the operating instructions as an improper adjustment of other controls may result in damage and will often require extensive work by a qualified technician to restore the equipment to its normal operation. E. If the equipment has been dropped, or the cabinet damaged. F. When the equipment exhibits a distinct change in performance — this indicates a need for service.</p> <p>14. Replacement Parts When replacement parts are required, be sure the service technician has used replacement parts specified by the manufacturer or that have the same characteristics as the original part. Unauthorized substitutions may result in fire, electric shock or other hazards.</p> <p>15. Safety Check Upon completion of any service or repairs to this equipment, ask the service technician to perform safety checks to determine that the equipment is in proper operating condition.</p> <p>16. Field Installation This installation should be made by a qualified service person and should conform to all local codes.</p> <p>17. Correct Batteries Warning: Risk of explosion if battery is replaced by an incorrect type. Dispose of used batteries according to the instructions.</p> <p>18. Tmra A manufacturer's maximum recommended ambient temperature (Tmra) for the equipment must be specified so that the customer and installer may determine a suitable maximum operating environment for the equipment.</p> <p>19. Elevated Operating Ambient Temperature If installed in a closed or multi-unit rack assembly, the operating ambient temperature of the rack environment may be greater than room ambient. Therefore, consideration should be given to installing the equipment in an environment compatible with the manufacturer's maximum rated ambient temperature (Tmra).</p> <p>20. Reduced Air Flow Installation of the equipment in the rack should be such that the amount of airflow required for safe operation of the equipment is not compromised.</p> <p>21. Mechanical Loading Mounting of the equipment in the rack should be such that a hazardous condition is not caused by uneven mechanical loading.</p> <p>22. Circuit Overloading Consideration should be given to connection of the equipment to supply circuit and the effect that overloading of circuits might have on over current protection and supply wiring. Appropriate consideration of equipment nameplate ratings should be used when addressing this concern.</p> <p>23. Reliable Earthing (Grounding) Reliable grounding of rack mounted equipment should be maintained. Particular attention should be given to supply connections other than direct connections to the branch circuit (e.g., use of power strips).</p> |
|--|---|

Table of Contents

| | |
|--|----|
| Chapter 1 — Introduction | 1 |
| Features | 1 |
| Technical Overview | 2 |
| Chapter 2 — Installation | 3 |
| Package Contents | 3 |
| Required Installation Tools | 3 |
| Setting Unit for NTSC or PAL | 3 |
| Connecting the Video Source | 4 |
| Connecting the Loop Through Video | 4 |
| Connecting the Monitor | 5 |
| Connecting Audio | 5 |
| Connecting Alarms | 6 |
| AI 1 to 16 (Alarm In) | 6 |
| GND (Ground) | 6 |
| AO 1 TO 4 (Alarm Out) | 6 |
| ARI (Alarm Reset In) | 6 |
| Connecting to the RS485 | 7 |
| Connecting to the Network Port | 7 |
| Connecting to the Modem Port | 7 |
| Connecting to the USB Port | 8 |
| Connecting to the Ultra Wide SCSI Port | 8 |
| Connecting to the RS232 Port | 9 |
| Factory Reset | 9 |
| Connecting the Power Cord | 10 |
| Chapter 3 — Configuration | 11 |
| Front Panel Controls | 11 |
| Up, Down, Left, Right Arrow Buttons | 11 |
| Enter Button | 11 |
| Camera Buttons (1 to 16) | 11 |
| MENU Button | 12 |
| DISPLAY Button | 12 |
| SEQUENCE Buttons | 12 |
| FREEZE Button | 12 |
| TALK Button | 12 |
| COUNTER Button | 12 |
| SPOT Button | 13 |
| PTZ Button | 13 |

| | |
|---|----|
| ALARM Button | 13 |
| SEARCH Button | 13 |
| PLAY/PAUSE Button | 13 |
| STOP Button..... | 13 |
| RW (Rewind) Button | 13 |
| FF (Fast Forward) Button..... | 14 |
| REC (Record) Button | 14 |
| Shuttle Ring | 14 |
| Jog Dial..... | 14 |
| Microphone | 14 |
| VOLUME Control | 14 |
| Speaker | 14 |
| Turning on the Power | 15 |
| Review of Front Panel Display | 15 |
| Initial Unit Setup | 16 |
| Quick Setup Screen | 16 |
| Normal Setup Screen | 18 |
| System Information..... | 18 |
| Date/Time Setup..... | 21 |
| System Check Screen | 24 |
| Storage Screen..... | 25 |
| System Log Screen | 27 |
| System Shutdown..... | 28 |
| Configuring Input Devices | 28 |
| Camera Setup Screen | 29 |
| Alarm In Setup Screen..... | 30 |
| Motion Detector | 31 |
| Alarm Out Setup Screen..... | 33 |
| Audio Setup Screen..... | 35 |
| RS232/RS485 Setup Screen | 36 |
| Configuring Recording Settings..... | 37 |
| Record Mode Setup Screen..... | 37 |
| Time-Lapse Record Mode Setup Screen..... | 38 |
| Time-Lapse Recording Schedule..... | 39 |
| Pre-Event Recording Setup Screen..... | 40 |
| Event Action Setup..... | 41 |
| Alarm In Event Action (Record) Setup Screen..... | 42 |
| Alarm In Event Action (Alarm Out) Setup Screen | 43 |
| Alarm In Event Action (Notify) Setup Screen | 44 |
| Motion Detector Event Action (Record) Setup Screen..... | 45 |
| Motion Detector Event Action (Alarm Out) Setup Screen | 46 |
| Motion Detector Event Action (Notify) Setup Screen | 47 |

| | |
|--|----|
| Video Loss Event Action (Record) Setup Screen | 48 |
| Video Loss Event Action (Alarm Out) Setup Screen | 49 |
| Video Loss Event Action (Notify) Setup Screen | 50 |
| Display Setup | 51 |
| OSD (On-Screen Display) Setup | 51 |
| Main Monitoring Setup Screen | 52 |
| Spot Monitoring Setup Screen | 53 |
| Network Setup Screen | 54 |
| LAN Setup Screen | 55 |
| Modem Setup | 56 |
| Callback Center Setup Screen | 57 |
| Password Setup Screen | 58 |
| Config Screen | 60 |
| Archive | 60 |
| Clip Copy | 62 |
| Load Default Setup | 64 |
| Clear All Data | 64 |
| | |
| Chapter 4 — Operation | 65 |
| Turning on the Power | 65 |
| Live Monitoring | 65 |
| Active Cameo Mode | 66 |
| PIP Mode | 66 |
| PTZ Mode | 67 |
| Recording Video | 68 |
| Recording Audio | 68 |
| Playing Recorded Video | 68 |
| RW (Rewind) Button | 68 |
| FF (Fast Forward) Button | 69 |
| STOP Button | 69 |
| Camera Buttons (1 to 16) | 69 |
| DISPLAY Button | 69 |
| Shuttle Ring | 69 |
| Jog Dial | 69 |
| Searching Video | 70 |
| Change Data Source | 70 |
| Date/Time Search | 71 |
| Calendar Search | 71 |
| Event Search | 72 |

| | |
|---|----|
| Appendix A — USB Hard Disk Drive Preparation | 75 |
| Preparing the USB-IDE hard disk drive in Windows 2000 | 75 |
| Preparing the USB-IDE hard disk drive in Windows 98 | 75 |
| Appendix B — Reviewing Backup (Clip) Images | 77 |
| Appendix C — Troubleshooting | 79 |
| Appendix D — Connector Pin Outs | 80 |
| I/O Connector Pin Outs | 80 |
| RS485 Connector Pin Outs | 80 |
| Observation Camera Connector Pin Outs | 81 |
| Appendix E — Map of Screens | 82 |
| Appendix F — Specifications | 83 |

List of Illustrations

| | |
|--|----|
| Figure 1 — Typical DVR installation. | 1 |
| Figure 2 — 16-Channel DVR rear panel. (Others are similar.)..... | 3 |
| Figure 3 — NTSC/PAL switch. | 3 |
| Figure 4 — Video input connectors (1). | 4 |
| Figure 5 — Video input connectors (2). | 4 |
| Figure 6 — Video Loop Through connectors. | 4 |
| Figure 7 — Video Out connectors. | 5 |
| Figure 8 — Audio In and Out connectors. | 5 |
| Figure 9 — Alarm Input connector strips. | 6 |
| Figure 10 — Alarm Output connector strips. | 6 |
| Figure 11 — Alarm Reset Input connector strips. | 6 |
| Figure 12 — RS485 Connector. | 7 |
| Figure 13 — Network connector. | 7 |
| Figure 14 — Modem connector. | 7 |
| Figure 15 — USB connector. | 8 |
| Figure 16 — SCSI connector. | 8 |
| Figure 17 — RS232 connector. | 9 |
| Figure 18 — Factory reset switch. | 9 |
| Figure 19 — Power cord connector. | 10 |
| Figure 20 — 16-Channel DVR front panel. (Others are similar.)..... | 11 |
| Figure 21 — Front panel display. | 15 |
| Figure 22 — Admin Password screen. | 16 |
| Figure 23 — Quick Setup screen. | 16 |
| Figure 24 — Normal Setup screen. | 18 |
| Figure 25 — System Information screen. | 18 |
| Figure 26 — System Information Change screen. | 19 |
| Figure 27 — Virtual keyboard. | 19 |
| Figure 28 — System Upgrade screen. | 20 |
| Figure 29 — Date/Time setup screen. | 21 |
| Figure 30 — Holiday Setup screen. | 22 |
| Figure 31 — Time Sync screen. | 22 |
| Figure 32 — System Check screen. | 24 |
| Figure 33 — Storage screen. | 25 |
| Figure 34 — S.M.A.R.T. Setup screen. | 26 |
| Figure 35 — System Log screen. | 27 |
| Figure 36 — Device menu screen. | 28 |
| Figure 37 — Camera setup screen. | 29 |
| Figure 38 — PTZ Device list. | 30 |
| Figure 39 — Alarm In setup screen. | 30 |
| Figure 40 — Motion Detector setup screen. | 31 |
| Figure 41 — Motion Detection Zone screen. | 32 |
| Figure 42 — Motion Detection Zone menu screen. | 32 |
| Figure 43 — Alarm Out setup screen. | 33 |
| Figure 44 — Alarm Out Schedule screen. | 34 |
| Figure 45 — Audio Setup screen. | 35 |
| Figure 46 — RS232/RS485 setup screen. | 36 |
| Figure 47 — Record Mode Setup screen. | 37 |
| Figure 48 — Time-Lapse Record Setup screen. | 38 |
| Figure 49 — Time-Lapse Recording Schedule screen. | 39 |
| Figure 50 — Pre-Event Record Setup screen. | 40 |
| Figure 51 — Alarm In Event Action (Record) setup screen. | 42 |
| Figure 52 — Alarm In Event Action (Alarm Out) setup screen. | 43 |
| Figure 53 — Alarm In Event Action (Notify) setup screen. | 44 |

| | |
|--|----|
| Figure 54 — Motion Detector Event Action (Record) setup screen..... | 45 |
| Figure 55 — Motion Detector Event Action (Alarm Out) setup screen..... | 46 |
| Figure 56 — Motion Detector Event Action (Notify) setup screen..... | 47 |
| Figure 57 — Video Loss Event Action (Record) setup screen..... | 48 |
| Figure 58 — Video Loss Event Action (Alarm Out) setup screen..... | 49 |
| Figure 59 — Video Loss Event Action (Notify) setup screen..... | 50 |
| Figure 60 — OSD Setup screen..... | 51 |
| Figure 61 — Main Monitoring Setup screen..... | 52 |
| Figure 62 — Spot Monitoring Setup screen..... | 53 |
| Figure 63 — Network Setup screen..... | 54 |
| Figure 64 — LAN Setup screen..... | 55 |
| Figure 65 — Modem Setup screen..... | 56 |
| Figure 66 — Callback Center Setup screen..... | 57 |
| Figure 67 — Password setup screen..... | 59 |
| Figure 68 — Config screen..... | 60 |
| Figure 69 — Archive screen..... | 60 |
| Figure 70 — Archive Setup screen..... | 61 |
| Figure 71 — Manual Archive screen..... | 62 |
| Figure 72 — Clip Copy screen..... | 63 |
| Figure 73 — PTZ Preset screen..... | 67 |
| Figure 74 — Preset view screen..... | 67 |
| Figure 75 — Search Menu..... | 70 |
| Figure 76 — Change Data Source screen..... | 70 |
| Figure 77 — Date/Time Search screen..... | 71 |
| Figure 78 — Calendar Search screen..... | 71 |
| Figure 79 — Event Log screen..... | 72 |
| Figure 80 — Event Search (by Camera) screen..... | 73 |
| Figure 81 — Event Search (by Event) screen..... | 73 |
| Figure 82 — Player screen..... | 77 |

Chapter 1 — Introduction

Features

Your color digital video recorder (DVR) provides recording capabilities for four, nine or 16 camera inputs. It provides exceptional picture quality in both live and playback modes, and offers the following features:

- 4, 9 or 16 Composite Input Connectors
- Compatible with Color (NTSC or PAL) and B&W (CCIR and EIA-170) Video Sources
- Multiple Search Engines (Date/Time, Calendar, Event)
- Records up to 60 NTSC Images per Second (50 PAL Images per Second)
- “Loop-Through” Video Connectors
- Continuous Recording in Disk Overwrite Mode
- Front Panel Displays Time, Date, Recording Mode and Remaining Storage Capacity and More
- Video Archiving via Ultra SCSI Interface
- Continues Recording while Archiving, Transmitting to Remote Site and during Playback
- User-friendly Graphical User Interface (GUI) Menu System
- Two Record Modes (Time and Event)
- Audio Recording and Playback
- Alarm Connections Include: Input, Output and Reset Input
- Built-in Alarm Buzzer
- Live or Recorded Video Access via Ethernet or Modem

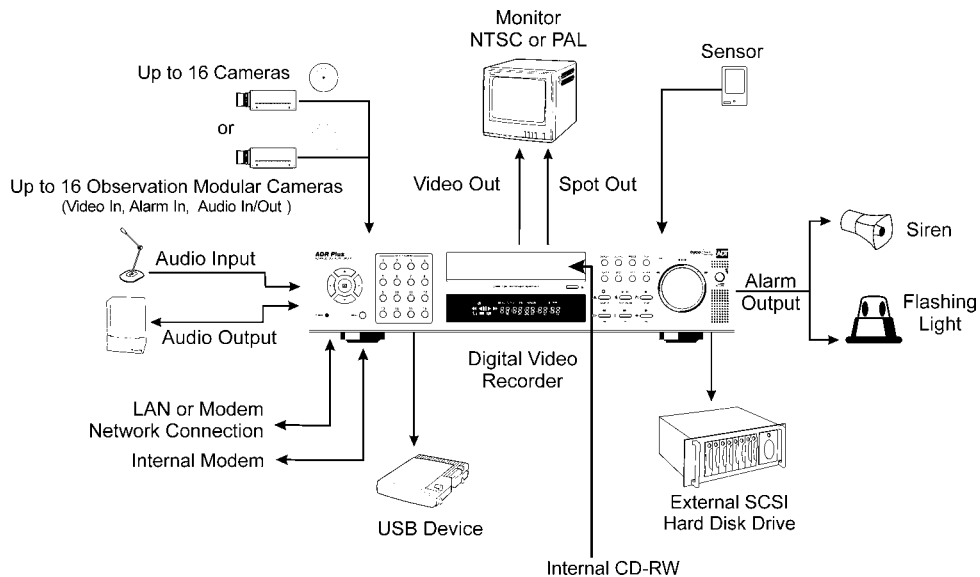

Figure 1 — Typical DVR installation.

Technical Overview

Your DVR can replace both a time-lapse VCR and a multiplexer in a security installation. However, it has many features that make it much more powerful and easier to use than even the most advanced VCR.

The DVR converts analog NTSC or PAL video to digital images and records them on a hard disk drive. Using a hard disk drive allows you to access recorded video almost instantaneously; there is no need to rewind tape. The technology also allows you to view recorded video while the DVR continues recording video.

Digitally recorded video has several advantages over analog video recorded on tape. There is no need to adjust tracking. You can freeze frames, fast forward, fast reverse, slow forward and slow reverse without image streaking or tearing. Digital video can be indexed by time or events, and you can instantly view video after selecting the time or event.

Your DVR can be set up for event or time-lapse recording. You can define times to record, and the schedule can change for different days of the week and user defined holidays.

The DVR can be set up to alert you when the hard disk drive is full, or it can be set up to record over the oldest video once the disk is full.

Your DVR uses a proprietary encryption scheme making it nearly impossible to alter video.

You can view video and control your DVR remotely by connecting via modem or Ethernet. There is a SCSI port that can be used to record or archive video to external hard disk drives, and also there is a USB port that can be used to back up the clip file video to external hard disk drives or CD-RW drives.

NOTE: This manual covers the 4-, 9- 16-channel digital video recorders. The DVRs are identical except for the number of cameras and alarms that can be connected and the number of cameras that can be displayed. For simplicity, the illustrations and descriptions in this manual refer to the 16-camera model.

Chapter 2 — Installation

Package Contents

The package contains the following:

- Digital Video Recorder
- Power Cord
- Adaptor
- User's Manual (This Document)
- RAS Software Diskettes and User's Manual
- Rack-mount Kit
- Assembly Screws for Adding Hard Disk Drives
- BNC Cable, SVHS Cable, and RJ-11 Telephone Modem Cable

Required Installation Tools

No special tools are required to install the DVR. Refer to the installation manuals for the other items that make up part of your system.

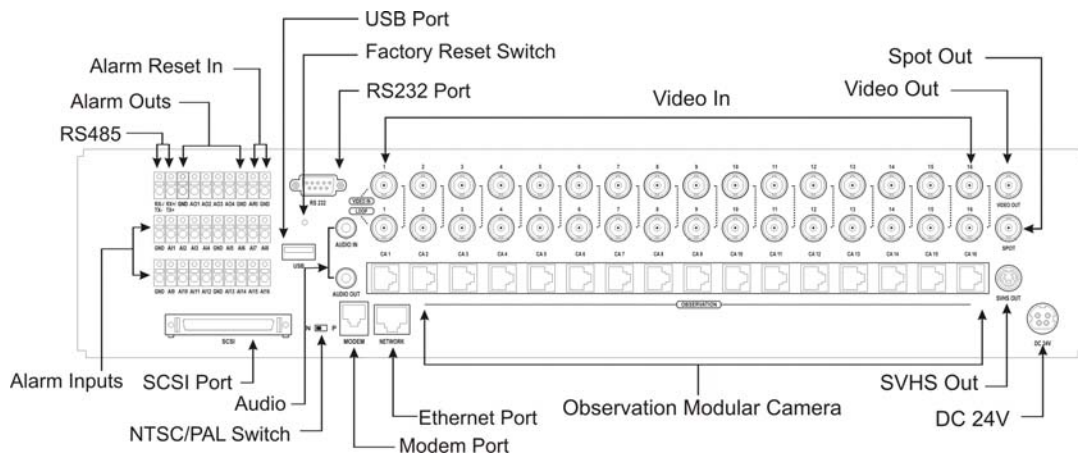

Figure 2 — 16-Channel DVR rear panel. (Others are similar.)

Setting Unit for NTSC or PAL

N P

Figure 3 — NTSC/PAL switch.

Your DVR can be used with either NTSC or PAL equipment. Before turning on the DVR, set the switch to NTSC or PAL to match your equipment.

NOTE: You cannot mix NTSC and PAL equipment. For example you cannot use a PAL camera and an NTSC monitor.

CAUTION: If you set the switch from NTSC (PAL) to PAL (NTSC), please do the *Factory Reset* and *Clear All Data*. If not, it causes the DVR to perform wrong operations.

Connecting the Video Source

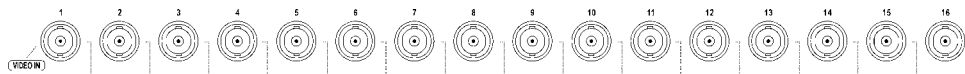

Figure 4 — Video input connectors (1).

Connect the coaxial cables from the video sources to the BNC Video In connectors.

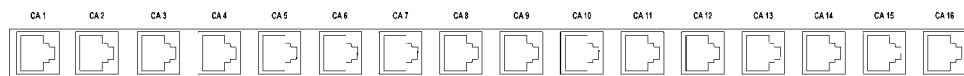

Figure 5 — Video input connectors (2).

Connect the RJ-11 cables from the observation cameras to the modular RJ-11 connectors.

CAUTION: Do NOT attempt to use the modular input and BNC input for the same camera port.

Connecting the Loop Through Video

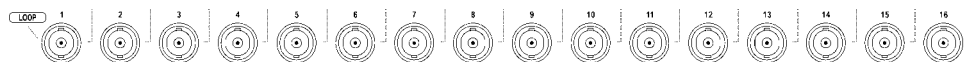

Figure 6 — Video Loop Through connectors.

If you would like to connect your video source to another device, you can use the Loop BNC connectors.

NOTE: The Loop BNC connectors are auto terminated. Do NOT connect a cable to the Loop BNC unless it is connected to another terminated device because it will cause poor quality video.

Connecting the Monitor



Figure 7 — Video Out connectors.

Connect the monitor to either the Video Out or SVHS Out connector.

Connect the spot monitor to the SPOT connector if required.

NOTE: If your monitor has an SVHS input, use it because it will give you better quality video display.

NOTE: The *Video Out* (BNC) and the *SVHS Out* connectors may be connected to individual monitors for simultaneous operation.

Connecting Audio

NOTE: It is the user's responsibility to determine if local laws and regulations permit recording audio.



Figure 8 — Audio In and Out connectors.

Your DVR can record audio. Connect the audio source to Audio In. Connect Audio Out to your amplifier.

NOTE: The DVR does not have amplified audio output, so you will need a speaker with an amplifier. The audio input can be from an amplified source or directly from a microphone.

NOTE: When connecting the observation camera with built-in microphone, the audio from that camera is heard on the DVR speaker or audio output.

Connecting Alarms

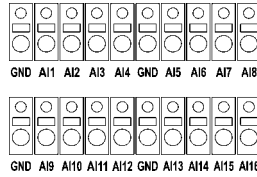

Figure 9 — Alarm Input connector strips.

NOTE: To make connections on the Alarm Connector Strip, press and hold the button and insert the wire in the hole below the button. After releasing the button, tug gently on the wire to make certain it is connected. To disconnect a wire, press and hold the button above the wire and pull out the wire.

AI 1 to 16 (Alarm In)

You can use external devices (including alarm input on the observation camera) to signal the DVR to react to events. Mechanical or electrical switches can be wired to the AI (Alarm In) and GND (Ground) connectors. The threshold voltage is 4.3V and should be stable at least 0.5 seconds to be detected. See *Chapter 3 — Configuration* for configuring alarm input.

GND (Ground)

NOTE: All the connectors marked GND are common.

Connect the ground side of the Alarm input and/or alarm output to the GND connector.

AO 1 TO 4 (Alarm Out)

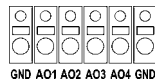

Figure 10 — Alarm Output connector strips.

The DVR can activate external devices such as buzzers or lights. Connect the device to the AO (Alarm Out) and GND (Ground) connectors. AO is an active low open collector output which sinks 5mA@12V and 30 mA@5V. See *Chapter 3 — Configuration* for configuring alarm output.

ARI (Alarm Reset In)



Figure 11 — Alarm Reset Input connector strips.

An external signal to the **Alarm Reset In** can be used to reset both the Alarm Out signal and the DVR's internal buzzer. Mechanical or electrical switches can be wired to the AI (Alarm In) and GND (Ground) connectors. The threshold voltage is 4.3V and should be stable at least 0.5 seconds to be detected. Connect the wires to the **ARI** (Alarm Reset In) and **GND** (Ground) connectors.

Connecting to the RS485



Figure 12 — RS485 Connector.

The DVR can be controlled remotely by an external device or control system, such as a control keyboard, using RS485 half-duplex serial communications signals. The RS485 connector can also be used to control PTZ (pan, tilt, zoom) cameras. Connect RX-/TX- and RX+/ TX+ of the control system to the TX-/RX- and TX+/RX+ (respectively) of the DVR. See *Chapter 3 — Configuration* and the PTZ camera or remote controller manufacture's manual for configuring the RS485 connection.

Connecting to the Network Port

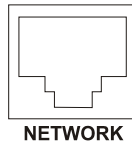

Figure 13 — Network connector.

The DVR can be networked using the 10/100Mb Ethernet connector. Connect a Cat5 cable with an RJ-45 jack to the DVR connector. The DVR can be networked with a computer for remote monitoring, searching, configuration and software upgrades. See *Chapter 3 — Configuration* for configuring the Ethernet connections.

Connecting to the Modem Port

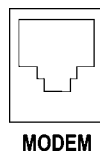

Figure 14 — Modem connector.

The DVR can be networked using the telephone line connector. Connect a cable with an RJ-11 jack to the DVR connector. The DVR can be networked with a computer for remote monitoring, searching, configuration and software upgrades. See *Chapter 3 — Configuration* for configuring the modem connections.

Connecting to the USB Port



Figure 15 — USB connector.

A USB port is provided to connect external hard disk drives for clip copying video. Position the external hard disk drive close enough to the DVR so that you can make the cable connections, usually less than 6 feet. Use the USB cable provided with the hard disk drive to connect it to the DVR.

Connecting to the Ultra Wide SCSI Port

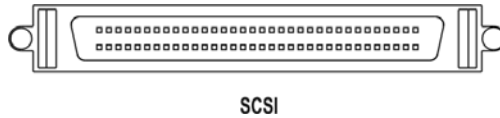

Figure 16 — SCSI connector.

A SCSI port is provided to connect external storage devices for recording or archiving video. Connect the external SCSI hard disk drive (RAID) cable to the high-density 68-pin female UltraWide SCSI port. The length of SCSI cable should not exceed 1.5 meters. You can connect up to four UltraWide SCSI devices with SCSI IDs set to 0, 1, 2, and 3 respectively.

NOTE: The SCSI bus must be terminated properly, otherwise the DVR will not operate properly.

CAUTION: Do NOT connect the SCSI device while the SCSI DVR power is on. SCSI devices cannot be connected to the DVR while it is operating.

CAUTION: If the SCSI device is shut down while the device is operating, the DVR system may not work normally.

Connecting to the RS232 Port

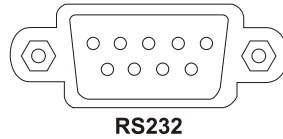
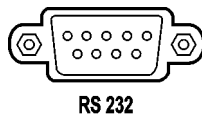

Figure 17 — RS232 connector.

An RS232 port is provided to connect an external modem for remote monitoring, configuration and software upgrades, and to connect a remote control keyboard. Use a modem cable with a DB-9S (female) connector to connect to the DVR. See *Chapter 3 — Configuration* for configuring the modem.

NOTE: The DVR is not supplied with a modem cable, and many modems are not supplied with cables. Make certain you have the correct cable when purchasing the modem.

Factory Reset



○ ← Factory Reset Switch

Figure 18 — Factory reset switch.

The DVR has a **Factory Reset** switch under the RS232 connector. This switch will only be used on the rare occasions that you want to return all the settings to the original factory settings.

CAUTION: When using the **Factory Reset**, you will lose any setting you have made.

To reset the unit, you will need a straightened paperclip:

1. Turn the DVR off.
2. Turn it on again.
3. While the DVR is initializing, poke the straightened paperclip in the unlabeled hole to the right of the RS232 connector.
4. Hold the switch until all the LEDs and all the segments on the Front Panel Display are lit.

NOTE: When the DVR successfully resets to factory defaults all the LEDs and the segments on the Front Panel Display flash three times.

5. Release the reset switch. All of the DVR's settings are now at the original settings it had when it left the factory.

Connecting the Power Cord

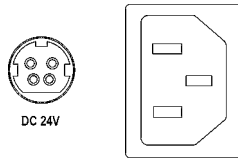

Figure 19 — Power cord connector.

Connect the DC power cord of the adaptor to the DVR, and connect the AC power cord to the adaptor and then to the wall outlet.

NOTE: The power cord connector locks into position to prevent accidental power loss. Be sure to slide the release away from the socket before removing the plug.

WARNING: ROUTE POWER CORDS SO THAT THEY ARE NOT A TRIPPING HAZARD. MAKE CERTAIN THE POWER CORD WILL NOT BE PINCHED OR ABRADED BY FURNITURE. DO NOT INSTALL POWER CORDS UNDER RUGS OR CARPET.

THE POWER CORD HAS A GROUNDING PIN. IF YOUR POWER OUTLET DOES NOT HAVE A GROUNDING PIN RECEPTACLE, DO NOT MODIFY THE PLUG. DO NOT OVERLOAD THE CIRCUIT BY PLUGGING TOO MANY DEVICES IN TO ONE CIRCUIT.

Your DVR is now ready to operate. Refer to *Chapter 3 — Configuration* and *Chapter 4 — Operation*.

Chapter 3 — Configuration

NOTE: Your DVR should be completely installed before proceeding. Refer to *Chapter 2 — Installation*.

Front Panel Controls

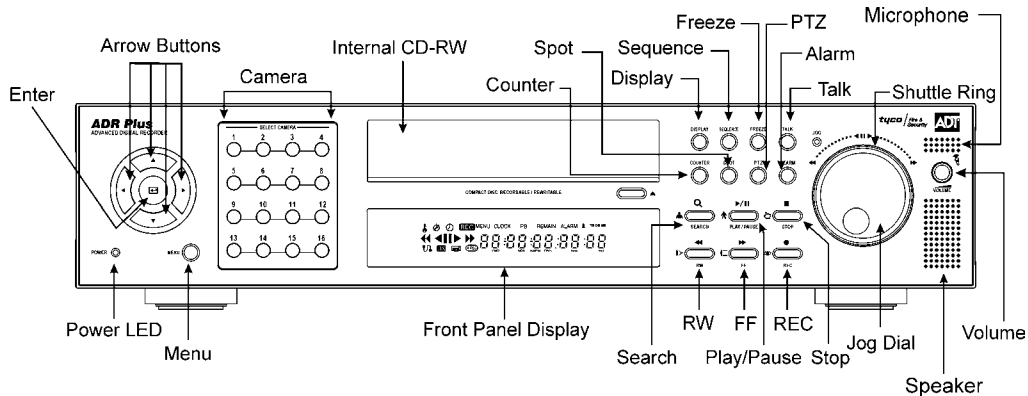



Figure 20 — 16-Channel DVR front panel. (Others are similar.)

The front panel looks and operates much like a VCR combined with a multiplexer. Many of the buttons have multiple functions. The following describes each button and control. Take a few minutes to review the descriptions. You will use these to initially set up your DVR and for daily operations.

Up, Down, Left, Right Arrow Buttons

These buttons are used to navigate through menus and GUI. They are also used to control Pan and Tilt when in the PTZ mode. The arrow buttons can be used to move the position of the active cameo screen, and also move through screen pages.

Enter Button

The  (Enter) button selects a highlighted item or completes an entry that you have made during system setup. This is also used to enter or exit the active cameo mode during live monitoring and playback.

Camera Buttons (1 to 16)

Pressing the individual camera buttons will cause the selected camera to display full screen. They are also used to enter passwords.

MENU Button

Pressing the **MENU** button enters the **Normal Setup** screen. You will need to enter the administrator password to access the Normal Setup. Pressing the button also closes the current menu or setup dialog box.

DISPLAY Button

Pressing the **DISPLAY** button toggles between different display formats. The available formats are: full, 4x4, 3x3, 2x2 and PIP.

SEQUENCE Buttons

When in the live mode, pressing the **SEQUENCE** button displays another full live channel sequentially. When in one of the multi-view formats, pressing this button will cause the DVR to sequence cameras in two sequence modes: "Page" and "Cameo". In the Page mode, the DVR sequences through user-defined screen layouts (pages). In the Cameo mode, the bottom, right screen to display live cameras sequentially. Pressing the **SEQUENCE** button while in the Sequence mode will exit the Sequence mode.

FREEZE Button

Pressing the **FREEZE** button freezes the current live screen.

TALK Button

Pressing and holding the **TALK** button sends audio from the DVR's built-in microphone to an optional intercom. The user can select the audio channel. While in the full-screen mode, the camera channel on the screen will be the audio channel you are using. While in the multi-screen mode, enter the active cameo mode first and then press the **TALK** button. The **TALK** button LED will be lit and the camera channel in a cameo window will be the audio channel. If you want to select another audio channel, move the cameo window to a desirable camera channel by pressing the **←** button and using arrow buttons. The speaker icon will be displayed on the video in a cameo window.

NOTE: During active cameo mode, the audio from the audio channel is heard on the DVR speaker or audio output, however, the user cannot send audio to an optional intercom. If you want to send audio, select a desirable audio channel and then exit from active cameo mode by pressing the **← button.**

NOTE: The TALK feature is operational only when the modular cameras are connected to the DVR, and *Observation* is selected for audio input during audio setup.

COUNTER Button

Pressing the **COUNTER** button switches between displaying the time and the remaining storage capacity on the front panel display.

SPOT Button

Pressing the **SPOT** button and pressing the individual camera buttons displays the selected camera on the spot monitor. For the sequence display on the spot monitor, press the **SPOT** button and then **SEQUENCE** button.

PTZ Button

Pressing the **PTZ** button opens a Pan/Tilt/Zoom screen which allows you to control properly configured cameras.

ALARM Button

The **ALARM** button has two functions. First, it will reset the DVR's outputs including the internal buzzer during an alarm. Second, it will display the event log when you are in the live monitoring mode unless there is an active alarm. This operation can be user password protected.

SEARCH Button

Pressing the **SEARCH** button displays the Search menu. Pressing the button again will exit the Search menu. This operation can be user password protected. Zooms In in PTZ mode.

PLAY/PAUSE Button

Pressing the **PLAY/PAUSE** button plays back images at regular speed. Pressing the button while in the playback mode will pause the video. The screen displays ► when the DVR is playing back video. The screen displays || when in the Pause mode. Zooms Out in PTZ mode.

Entering Playback mode from Live Monitoring mode can be user password protected.

STOP Button

Pressing the **STOP** button during Playback mode returns the DVR to the Live Monitoring mode. Saves Presets in PTZ mode.

RW (Rewind) Button

Pressing the **RW** button plays video backward at high speed. Pressing the button again toggles the playback speed from ◀◀, ◀◀◀ and ◀◀◀◀. The screen displays ◀◀, ◀◀◀ and ◀◀◀◀ respectively. Used for near Focus in the PTZ mode.

Entering Fast Backward Playback mode from Live Monitoring mode can be user password protected.

FF (Fast Forward) Button

Pressing the **FF** button plays video forward at high speed. Pressing the button again toggles the playback speed from **▶▶**, **▶▶▶** and **▶▶▶▶**. The screen displays **▶▶**, **▶▶▶** and **▶▶▶▶** respectively. Used for far Focus in PTZ mode.

Entering Fast Playback mode from Live Monitoring mode can be user password protected.

REC (Record) Button

Press the **REC** button to set the DVR so that it is ready to record video. A red dot appears on the screen and **REC** appears on the Front Panel Display when the DVR is recording video. Press the button again to stop recording video. This operation can be user password protected. Loads a Preset View in PTZ mode.

Shuttle Ring

The Shuttle Ring only functions in the Playback mode. The Shuttle Ring is spring loaded and returns to the center position when released. Turning the ring clockwise plays video forward. Turning the ring counterclockwise plays video backward. Playback speed varies with the amount the ring is turned. The playback speeds are **◀x0.5**, **◀◀**, **◀◀◀**, **◀◀◀◀**, **▶x0.5**, **▶▶**, **▶▶▶** and **▶▶▶▶**.

When you release the ring, it snaps back to the center position and the video pauses.

Jog Dial

The Jog Dial only functions when playback video has been paused. By turning the jog dial clockwise, you can play video forward image-by-image. By turning the jog dial counterclockwise, you play video backward image-by-image.

Microphone

The **Microphone** allows for two-way communication from the DVR to camera locations equipped with two-way audio. Press and hold the **TALK** button to talk into the microphone.

VOLUME Control

The **Volume** control adjusts the audio level of the communication from the camera. By turning the volume control clockwise, you can increase the volume level of the built-in speaker.

Speaker

The **Speaker** allows the user to monitor the audio from the camera or audio source.

Turning on the Power

Connecting the power cord to the DVR turns on the unit. The unit will take approximately 60 seconds to initialize.

Review of Front Panel Display

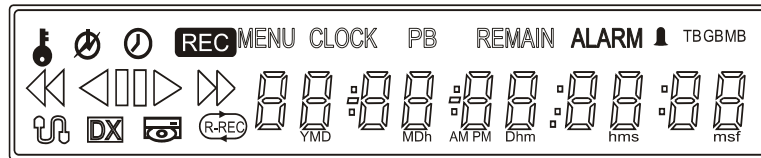















Figure 21 — Front panel display.

-  The key icon displays when the unit is in the Key Lock mode.
-  The circle with the broken line displays whenever the system was not properly shut down such as a power failure.
-  The clock icon displays when any camera is in the time-lapse mode.
- REC** REC displays while the unit is recording.
- MENU** MENU displays when the DVR is in Menu mode.
- CLOCK** CLOCK displays when the digits are displaying the current time.
- PB** PB displays when video is being played back and the digits are displaying the time of the recording.
- REMAIN** REMAIN displays when the digits are displaying the remaining hard disk drive capacity.
- ALARM** ALARM displays when any camera is in the event-driven recording mode.
-  The bell icon displays during alarm activation.
- TBGBMB** These light when the display is in the remaining disk capacity mode. TB = TeraBytes, GB = GigaBytes and MB = MegaBytes.
-  This icon displays when video is being played backward at fast speed.
-  This icon displays when video is being played backward at regular speed.
-  This icon displays when video is paused.
-  This icon displays when video is being played forward at regular speed.
-  This icon displays when video is being played forward at fast speed.
-  The network icon displays when the unit is networked either via Ethernet or modem.
-  DX displays when the DVR is operating in the Duplex mode.
-  The disk icon displays when data is being backed up.

 R-REC displays when the DVR is in the Repeat Record mode. The DVR will continue recording when the hard disk drive is full by recording over the oldest video.

 The digits display Time, Date and Remaining Capacity.

Initial Unit Setup

Before using your DVR for the first time, you will want to establish the initial settings. This includes items such as time and date, display language, camera, audio, remote control, record mode, network and password. Your DVR can be set up using various screens and dialog boxes.

Press the **MENU** button to enter the setup screens. The Admin Password screen appears.

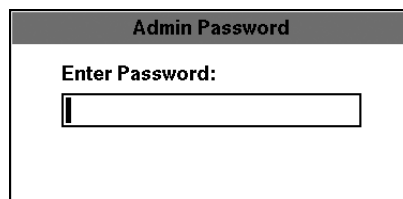

Figure 22 — Admin Password screen.

Enter the password by pressing the appropriate combination of Camera number buttons and then the Enter button. The factory default password is 4321. There are two Setup screens: Quick Setup and Normal Setup. The factory default is the Normal Setup screen.

Quick Setup Screen

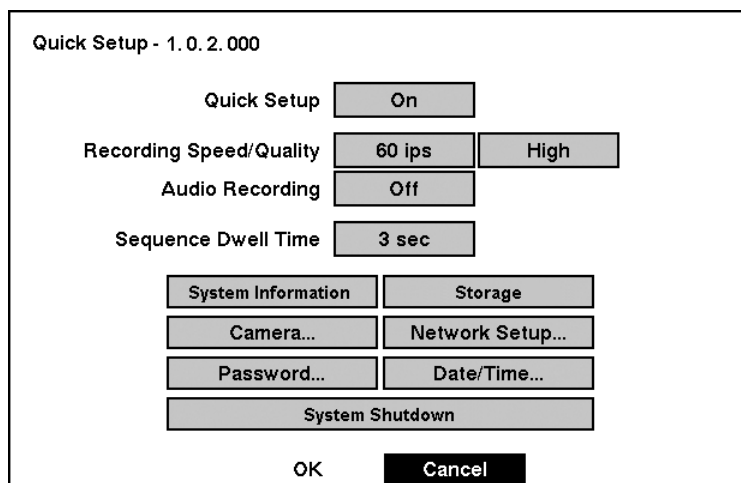



Figure 23 — Quick Setup screen.

The **Quick Setup** screen allows you to set up the most commonly used features of your DVR. Use the arrow buttons to move through the options. Pressing the  button lets you make your selections.

Highlight the box beside **Quick Setup** and press the  button to toggle between On and Off. If you select **Off**, you will use the **Normal Setup** screen to change the DVR's settings.

Highlight the **Record Speed** box and select recording speeds from as few as one image every 10 seconds to as fast as 60 ips.

NOTE: The DVR has a maximum recording speed of 60 ips per camera, however, the recording speed may not be achieved when averaged over all cameras.

Highlight the **Record Quality** box and select from Very High, High, Standard and Low.

Highlight the box beside **Audio Recording** and select either On or Off.

NOTE: It is the user's responsibility to determine if local laws and regulations permit recording audio.

Highlight the box beside **Sequence Dwell Time** and select from 3 to 60 seconds for the camera sequence dwell time.

Selecting **System Information...** enters that screen.

Selecting **Storage...** enters a screen where you can check the storage status.

Selecting **Camera...** enters a screen where you can set up camera information.

Selecting **Network Setup...** enters a screen where you can set up network information.

Selecting **Password...** enters a screen where you will be able to change passwords.

Selecting **Date/Time...** enters a screen where you will be able to set the DVR's time and date.

Selecting **System Shutdown...** shuts the DVR down. When shutting down the DVR, you need to confirm that you want to shut down the unit, you will be asked for an administrator password.

NOTE: The *Quick Setup* mode will be released automatically when the user changes the DVR settings remotely using the RAS(Remote Administration System) program.

Normal Setup Screen

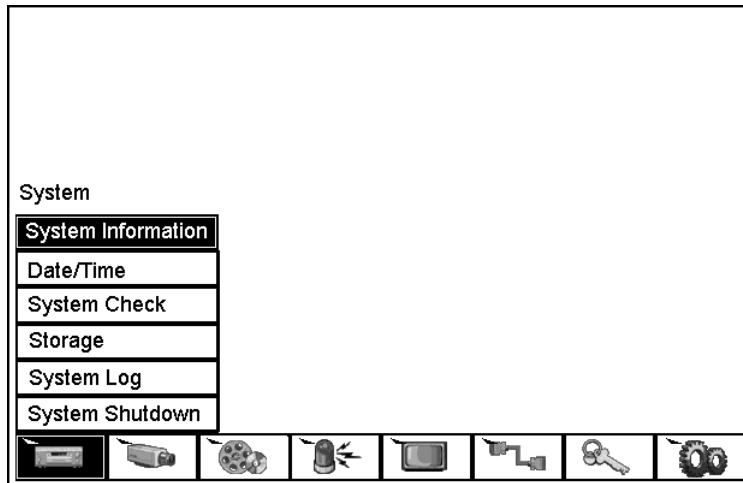

Figure 24 — Normal Setup screen.

Press the **MENU** button to enter the setup screen. If the Quick Setup screen appears, turn it off as described above. The Normal Setup screen gives you access to all the DVR's setup screens.

System Information

Highlight System Information and press the **↵** button. The System Information screen appears.

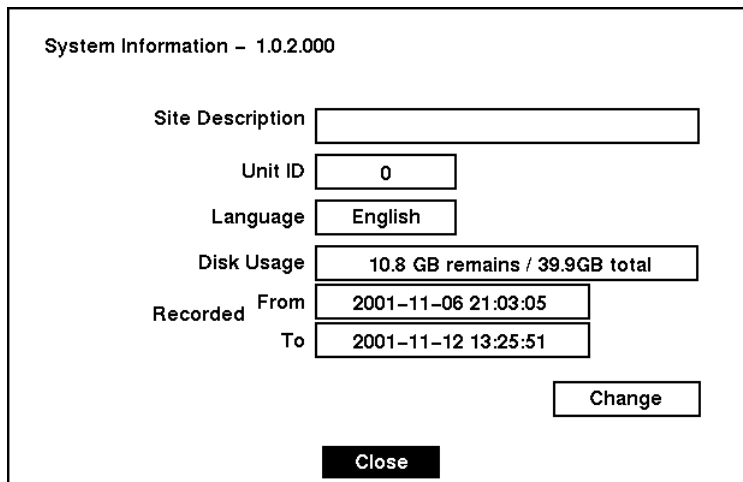

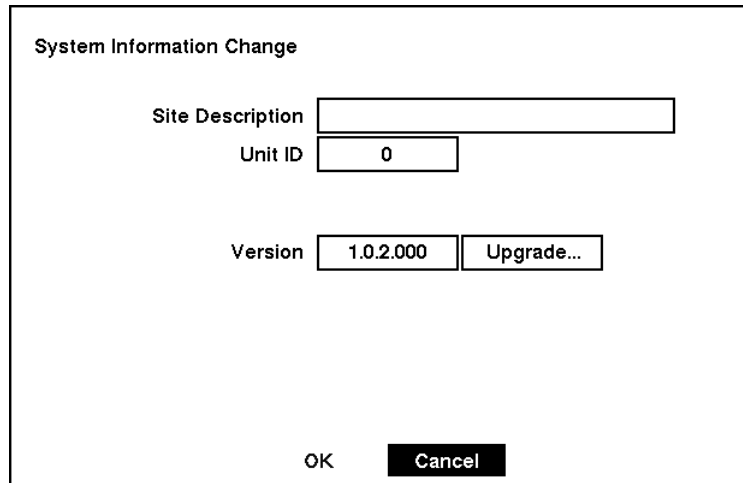



Figure 25 — System Information screen.

In the **System Information** screen, you can name the site location, assign a unit ID number and upgrade the software. Highlight **Change** and press the  button. The **System Information Change** screen appears.



The screenshot shows a window titled "System Information Change". It contains three input fields: "Site Description" (empty), "Unit ID" (containing "0"), and "Version" (containing "1.0.2.000"). To the right of the "Version" field is an "Upgrade..." button. At the bottom of the window are "OK" and "Cancel" buttons.



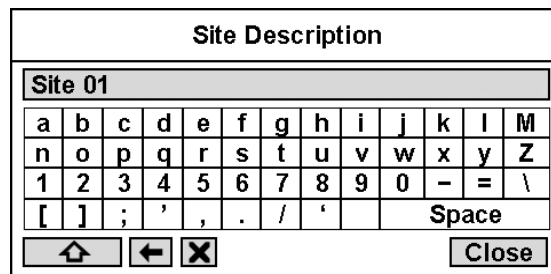

Figure 26 — System Information Change screen.

Highlight the box beside **Site Description** and press the  button. A virtual keyboard displays.





The screenshot shows a virtual keyboard titled "Site Description". The title bar contains "Site 01". The keyboard layout includes letters a-z, numbers 1-0, and symbols like semicolon, apostrophe, comma, period, slash, and space. At the bottom are navigation buttons: up arrow, left arrow, and a delete button (X), along with a "Close" button.

Figure 27 — Virtual keyboard.

Use the arrow keys to highlight the first character you want in the Site Title and press the  button. That character appears in the title bar and the cursor moves to the next position. Pressing  toggles between the upper and lower case keyboards,  backspaces, and  deletes entered characters. You can use up to 20 characters including spaces in your title.

Once you have entered your title, highlight **Close** and press the  button.

Highlight the box beside **Unit ID** and press the  button. Change the number by highlighting it and using the **Up** and **Down** arrow buttons to increase and decrease the number. The Unit ID number is used to identify the unit when it is networked with other DVRs. You cannot use the same number for two or more DVRs that are within the same network.

After you have created a title and assigned a unit ID number, you can save your changes by highlighting **OK** and pressing the  button. Selecting **Cancel** exits the screen without saving the changes.

The box beside **Version** displays the software and hardware version of the DVR. The first two digits are the hardware version and the last four digits are the software version. For example, “1.0.2.000” means that the hardware version is “1.0” and the software version is “2.000”.

NOTE: You can upgrade the software only in the *System Information Change* screen.

To upgrade the software, connect the USB device containing the upgrade package file to the DVR. Highlight **Upgrade...** and press the  button. The **System Upgrade** screen appears. The screen displays the upgrade package file name.

NOTE: If the file system on the USB-IDE hard disk drive or USB flash drive is NOT FAT16 or FAT32 format, format the drive using FAT16 or FAT32 format.

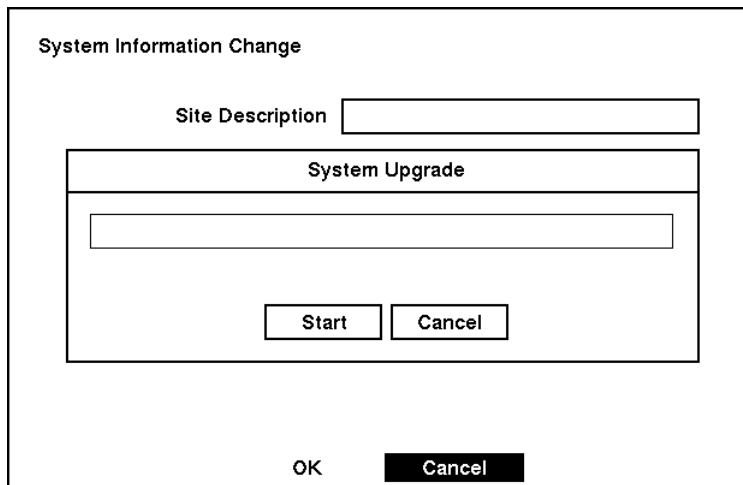



Figure 28 — System Upgrade screen.

Select **Start**, and enter the Admin password to start the upgrade. The system restarts automatically after completing the upgrade.

NOTE: Only the system administrator can upgrade the software.

NOTE: You cannot upgrade software during backup.

Date/Time Setup

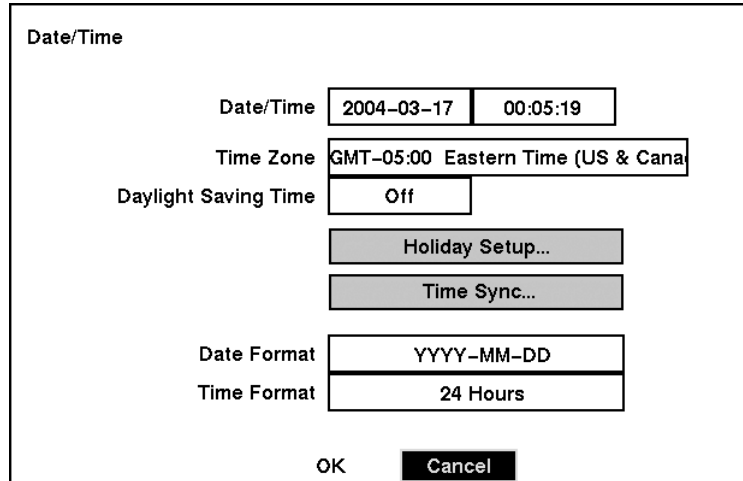

Highlight **Date/Time** in the Main menu and press the  button. The **Date/Time** setup screen appears.





| | |
|----------------------|------------------------------------|
| Date/Time | |
| Date/Time | 2004-03-17 00:05:19 |
| Time Zone | GMT-05:00 Eastern Time (US & Cana) |
| Daylight Saving Time | Off |
| | Holiday Setup... |
| | Time Sync... |
| Date Format | YYYY-MM-DD |
| Time Format | 24 Hours |
| OK Cancel | |



Figure 29 — Date/Time setup screen.

CAUTION: If you set a date and time that is older than some of your recorded images, any images with dates and times later than the new setting will be deleted.



Highlight the first box beside **Date/Time** and press the  button. The individual sections of the date highlight. Use the **Up** and **Down** arrow buttons to change the number. Use the **Left** and **Right** arrow buttons to move between month, date and year. Once you have the correct date, press the  button.



Highlight the second box beside **Date/Time** and press the  button. The individual sections of the time will highlight. Use the **Up** and **Down** arrow buttons to change the number. Use the **Left** and **Right** arrow buttons to move between hour, minutes and seconds. Once you have the correct time, press the  button.

NOTE: The clock will not start running until you have restarted the unit, so you may wish to set the time last.

Highlight the box beside **Time Zone** and press the  button. Select the time zone you are in from the list and press the  button.

Highlight the box beside **Daylight Saving Time** and press the  button. Pressing the  button toggles between **On** and **Off**.

Highlight the **Holiday Setup...** box and press the  button. You can set up holidays by highlighting **Add:** and pressing the  button. The current date appears.

Highlight the month and day and change them by using the Up and Down arrow buttons. Press the  button to add the date. Dates can be deleted by highlighting the X beside the date and pressing the  button.

NOTE: Holidays that do not fall on the same date each year should be updated once the current year's holiday has passed.

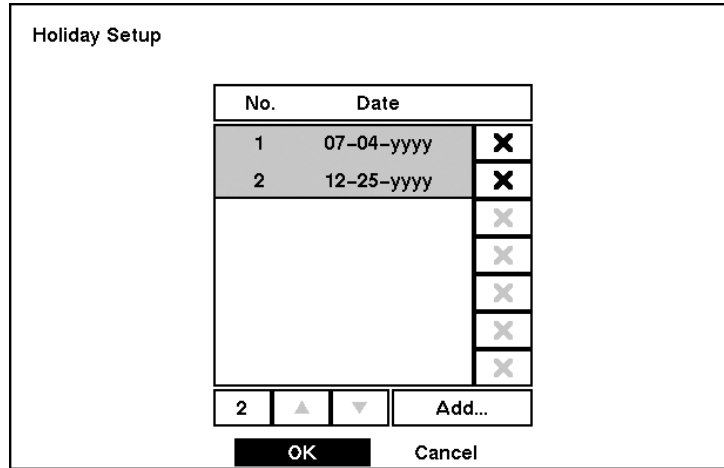



Figure 30 — Holiday Setup screen.

You can save your changes by highlighting OK and pressing the  button. Selecting Cancel exits the screen without saving the changes.

Highlight the Time Sync... box and press the  button. You can set up time synchronization between the DVR and standard time servers that are available in most time zones and countries, or between the DVR and another DVR.

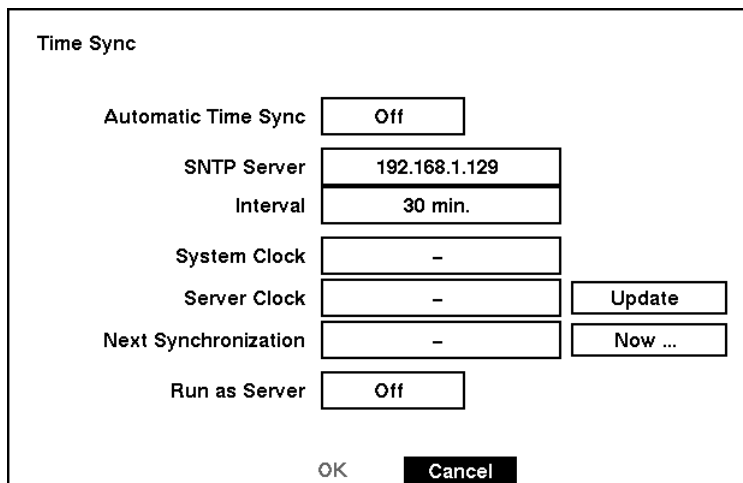

Figure 31 — Time Sync screen.

Highlight the box beside **Automatic Time Sync** and press the button. This toggles between On and Off.

Highlight the box beside **SNTP Server** and press the button. Change the numbers by highlighting them and using the **Up** and **Down** arrow buttons to increase or decrease the number value.

Highlight the box beside **Interval** and press the button. Set the time interval for synchronization from 1 to 300 minutes.

The box beside **System Clock** displays the DVR's time setting.

The box beside **Server Clock** displays the time setting of the time server. Highlighting the **Update** button and pressing the button updates the server clock.

NOTE: The *Server Clock* will display “ – ” when the DVR cannot load the time information from the time server.

The box beside **Next Synchronization** displays the time when the next synchronization is scheduled. If you want to synchronize the time instantly, highlight the **Now...** button and press the button.

CAUTION: When selecting *Now...*, any video with a later time and date will be lost if the time and date of a time server is earlier than the last recorded image of the DVR.

NOTE: When the time difference between the DVR and the time server is more than one minute, the DVR might not synchronize the time to prevent any unexpected loss of recorded video data. If you want to synchronize the time manually, select *Now...*

Highlight the **Run as Server** box and press the button. Pressing the button toggles between On and Off. When it is On, the DVR you are setting up will run as a time server.

You can save your changes by highlighting **OK** and pressing the button. Selecting **Cancel** exits the screen without saving the changes.

Highlight the box beside **Date Format** and press the button. A list of date formats appears. Highlight the format you wish to use and press the button. The choices are:

MM-DD-YYYY
DD-MM-YYYY
YYYY-MM-DD
MM/DD/YYYY
DD/MM/YYYY
YYYY/MM/DD

To change the time format, highlight the box beside **Time Format** and press the button. The DVR toggles between 12 Hours (AM/PM) and 24 Hours (military time).

You can save your changes by highlighting **OK** and pressing the button. Selecting **Cancel** exits the screen without saving the changes.

System Check Screen

Highlight **System Check** in the Main menu and press the button. The **System Check** setup screen appears.

The screenshot shows the 'System Check' screen with the following table:

| Check Point | On/Off | Interval | Status |
|-------------|--------|----------|--------|
| Record | On | 1 Hour | Good |
| Alarm In 1 | Off | 1 Hour | |
| Alarm In 2 | Off | 1 Hour | |
| Alarm In 3 | Off | 1 Hour | |
| Alarm In 4 | Off | 1 Hour | |

Below the table are four buttons: 1 - 4, 5 - 8, 9 - 12, and 13 - 16. Below these buttons is the text 'On Record Problem : Alarm Out' followed by a dropdown menu showing '-'. At the bottom are 'OK' and 'Cancel' buttons.

Figure 32 — System Check screen.

Highlight the box under the **On/Off** heading and press the button. This toggles between **On** and **Off**. When it is **On**, the DVR reports a fault condition if it does not detect any recording or if there is an alarm during the designated time.

Highlight the box under the **Interval** heading and press the button. A slide bar appears allowing you to set the check interval from 1 Hour to 30 Days by using the **Left** and **Right** arrow buttons.

The **Status** field displays the fault conditions. When it is **Good**, there was recording or an alarm occurred during the designated time. When it is **Bad**, there was no recording or no alarm occurred during the designated time.

Highlight the box beside the **On Record Problem: Alarm Out** and press the button. A drop menu displays the available alarm outputs for the recording problem. Highlight the desired alarm output from no alarm output, external alarm out terminal or internal buzzer, and press the button.

Storage Screen

Highlight **Storage** in the Main menu and press the  button. The **Storage** setup screen appears. The DVR displays the storage status when the installed IDE hard disk drives support the S.M.A.R.T. (Self-Monitoring Analysis and Reporting Technology) monitoring program.

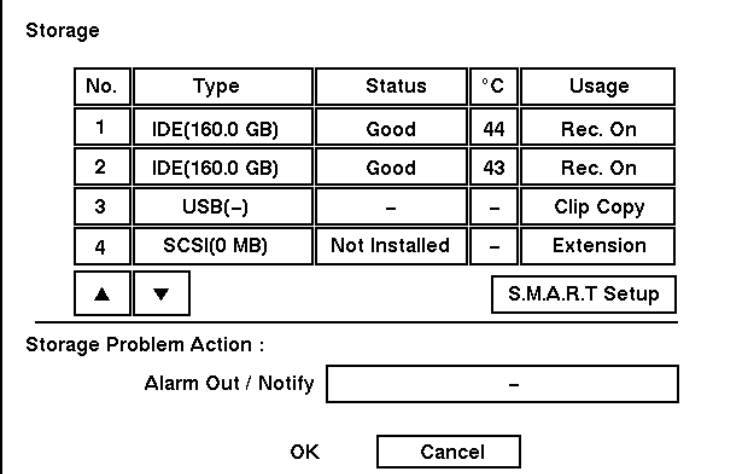

The screenshot shows the 'Storage' screen with a table of storage devices. Below the table are navigation arrows and an 'S.M.A.R.T. Setup' button. At the bottom, there is a 'Storage Problem Action' section with an 'Alarm Out / Notify' field and 'OK' and 'Cancel' buttons.

| No. | Type | Status | °C | Usage |
|-----|---------------|---------------|----|-----------|
| 1 | IDE(160.0 GB) | Good | 44 | Rec. On |
| 2 | IDE(160.0 GB) | Good | 43 | Rec. On |
| 3 | USB(-) | - | - | Clip Copy |
| 4 | SCSI(0 MB) | Not Installed | - | Extension |

▲ ▼ S.M.A.R.T. Setup

Storage Problem Action :

Alarm Out / Notify

OK

Figure 33 — Storage screen.

NOTE: When the DVR has more than four storage devices, you can scroll through the list by selecting the *Up* and *Down* arrow buttons under the list.

The **Type** field displays the type and capacity of storage devices.

The **Status** field displays “Good”, “Bad”, “S.M.A.R.T. Not work”, “S.M.A.R.T. Alert”, “High Temperature” or “Not installed”, depending on storage conditions.

- **Good** — The storage condition is normal.
- **Bad** — Data cannot be written on or read from the storage device.
- **S.M.A.R.T. Not work** — Storage conditions are normal, however, the S.M.A.R.T. monitoring is not working or supported
- **S.M.A.R.T. Alert** — S.M.A.R.T. monitoring has detected a fault condition.
- **High Temperature** — S.M.A.R.T. monitoring has detected that the temperature of storage device exceeded the preset temperature threshold.
- **Not installed** — The storage device is not installed.

NOTE: Once the “S.M.A.R.T. Alert” message displays, replacing the hard disk drive is recommended, usually within 24 hours.

NOTE: When the USB storage device is used for clip copy, storage size and status will not be displayed in the **Storage** screen.

The °C field displays the temperature of the storage device.

The Usage field displays the device usage.

NOTE: When the device is an IDE hard disk drive, you can change its usage to either *Rec. On* or *Rec. Off*. When the device is a SCSI hard disk drive, you can change its usage to either *Extension* or *Archive*.

CAUTION: A “–” displays when connecting a hard disk drive that was previously used for something else. In this situation, device usage can be changed as desired usages; e.g., *Extension* to *Archive* or *Archive* to *Extension*. However, data on the device will be lost if the device usage is changed.

The DVR can be set to react to storage problems by activating an internal buzzer or external alarms, and/or notifying a remote site. Highlight the box beside Storage Problem Action: Alarm Out / Notify and press the button to select from Beep, the alarm output terminal that you want to associate with the storage problem event, and/or Notify.

Highlight S.M.A.R.T. Setup... and press the button. The S.M.A.R.T. Setup screen appears.

The screenshot shows the S.M.A.R.T. Setup screen with the following fields and values:

| | |
|-----------------------|---------------------|
| Use | On |
| Last-check | 05-19-2004 23:48:10 |
| Period | Daily |
| Check Time | 21:47:48 |
| Temperature Threshold | 63 |
| Sensor Unit | Celsius |
| | Check Now |
| OK | Cancel |

Figure 34 — S.M.A.R.T. Setup screen.

Your DVR shows the condition of the hard disk drives if the installed IDE hard disk drives support the S.M.A.R.T. (Self-Monitoring, Analysis and Reporting Technology) program. Highlight the box beside Use. Press the button to toggle between On and Off.

The Last-check field displays the date and time information of the last storage check.

Highlight the box beside Period, and select from Daily, Weekly or Monthly for the check interval.

NOTE: When selecting *Weekly* or *Monthly*, the *Day of Week* or *Day of Month* field will display under the *Period* field. Select the check day or date.

Highlight the box beside Check Time, and adjust the numbers using arrow buttons.

Highlight the box beside Temperature Threshold and adjust the numbers using arrow buttons. Set the temperature number to the hard disk drive manufacturer's specifications. If this temperature is ever exceeded, the S.M.A.R.T. Alert message will display.

Highlight the box beside Sensor Unit and select from Celsius or Fahrenheit.

You can save your changes by highlighting OK and pressing the button. Selecting Cancel exits the screen without saving the changes.

System Log Screen

Highlight System Log in the Main menu and press the button. The System Log screen appears.

| System Log | | |
|------------|------------------------------|---------------------|
| No. | Event | Date/Time |
| 1283 | Setup Begin (Local) | 2002-01-24 10:27:14 |
| 1282 | System Started | 2002-01-24 10:27:12 |
| 1281 | Shutdown | 2002-01-24 10:27:02 |
| 1280 | System Time Changed | 2002-01-24 10:27:00 |
| 1279 | Setup Begin (Local) | 2002-01-24 10:26:08 |
| 1278 | System Started | 2002-01-24 10:26:02 |
| 1277 | Recovered from Power Failure | 2002-01-24 10:26:02 |

1283

Figure 35 — System Log screen.

The **System Log** screen displays a record of various events logged by the DVR. The list shows the dates and times the system was turned ON and OFF, power failed, recording was started or stopped, playback was started or stopped, setup changes were made, and data banks were cleared.

The events are listed from the most recent to the oldest. You can scroll through the list a page at a time by selecting the **Up** and **Down** arrow buttons and pressing the button. You can go directly to an event number by highlighting the event number box (left of the UP arrow), pressing the button, using the arrow buttons to change the number, and pressing the button.

System Shutdown

Highlight System Shutdown in the Main menu and press the  button. This shuts the DVR down. When shutting down the DVR, you need to confirm that you want to shut down the unit, and you will be asked for an administrator password.

Configuring Input Devices

You can configure the video, audio and remote control devices connected to the DVR.

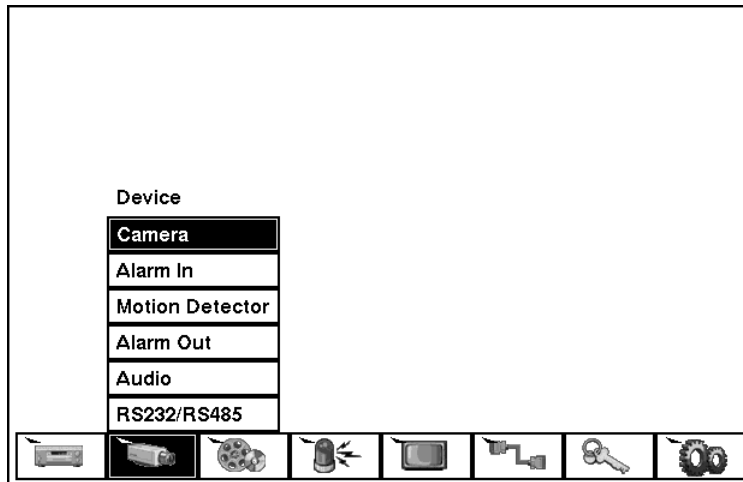

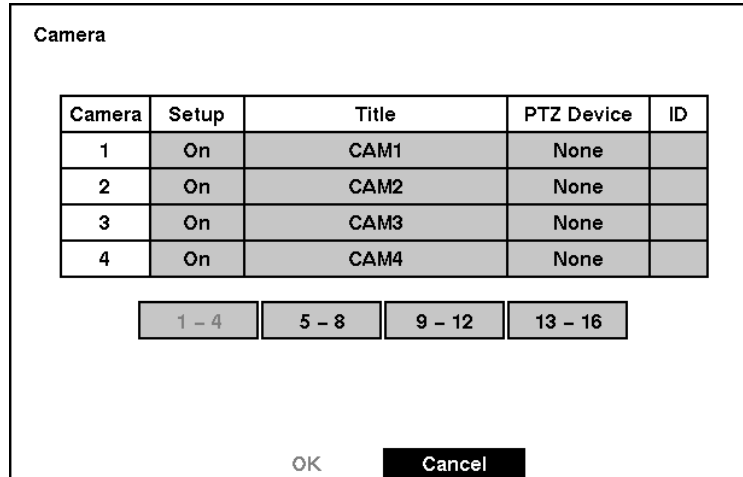

Figure 36 — Device menu screen.

Camera Setup Screen

Highlight **Camera** in the Main menu and press the  button. The **Camera** setup screen appears.



| Camera | Setup | Title | PTZ Device | ID |
|--------|-------|-------|------------|----|
| 1 | On | CAM1 | None | |
| 2 | On | CAM2 | None | |
| 3 | On | CAM3 | None | |
| 4 | On | CAM4 | None | |

1 - 4 5 - 8 9 - 12 13 - 16

OK Cancel

Figure 37 — Camera setup screen.

The **Camera** setup screen displays the camera inputs in groups of four: 1 to 4, 5 to 8, 9 to 12 and 13 to 16.

You can turn the camera number on or off and also hide the video from a camera by highlighting the camera **Setup** heading and pressing the  button. Select from **On**, **Off**, **Covert 1** or **Covert 2**.

NOTE: When set to **Covert 1**, the DVR displays the camera title and status icons on the covert video. When set to **Covert 2**, the DVR displays only the camera title on the covert video.

You can assign titles to each camera by highlighting the **Title** heading and pressing the  button. A virtual keyboard allows you to enter camera names.

Selecting **PTZ Device** causes a list of controllable cameras to display. Select your camera from the list and press the  button. You will need to connect the camera to the RS485 terminal on the back of the DVR following the camera manufacturer's instructions.

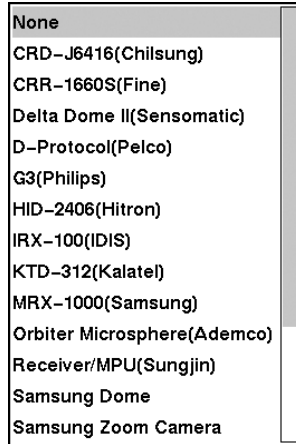

Figure 38 — PTZ Device list.

You can assign IDs to each camera by highlighting the ID heading and pressing the button. Change the number by highlighting it and using the Up and Down arrow buttons to increase and decrease the number. The PTZ ID number can be set from 0 to 256.

Alarm In Setup Screen

Highlight Alarm In in the Main menu and press the button. The Alarm In setup screen appears.

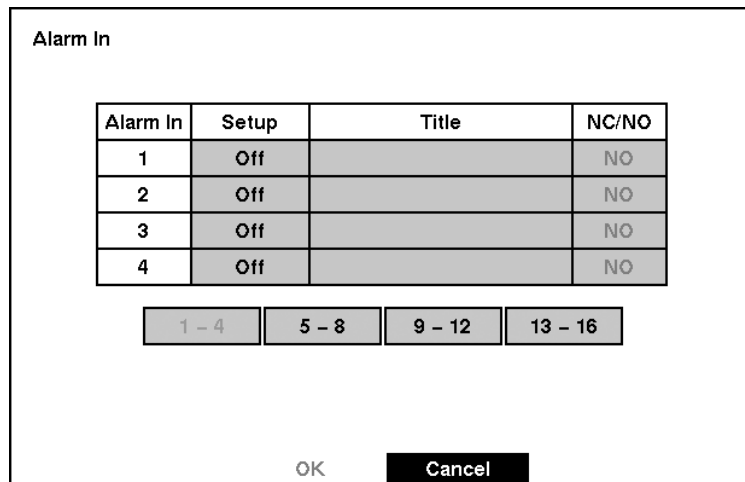





Figure 39 — Alarm In setup screen.

The alarm terminal strip on the back of the DVR has inputs associated with each alarm. You can set up each input on the Alarm In Setup screen. The inputs are displayed in groups of four. You can turn each input On (via Alarm I/O or Camera Alarm) or Off. Each input can be given a title, and the inputs can be set as NO (normally open) or NC (normally closed) independently.

Motion Detector

Motion Detector

| Camera | On/Off | Sensitivity | Zone | Min Size | View |
|--------|--------|-------------|---|----------|------|
| 1 | On | 3 |  | 10 | Off |
| 2 | On | 3 |  | 10 | Off |
| 3 | On | 3 |  | 10 | Off |
| 4 | On | 3 |  | 10 | Off |

1 - 4 5 - 8 9 - 12 13 - 16

OK **Cancel**

Figure 40 — Motion Detector setup screen.

Your DVR has built-in video motion detector. Video motion detector can be turned On or Off for each camera.

Highlighting the box under the **Sensitivity** heading allows you to adjust the DVR's sensitivity to motion. There are five settings with 1 being the least sensitive and 5 being the most sensitive.

You can adjust the minimum number of detection blocks that must be activated to trigger a motion alarm. Highlight a box under the **Min Size** heading and adjust the number. The smaller the number, fewer detection blocks must be activated and therefore more sensitive.

Turning the **View** setting On will allow you to observe how the DVR is reacting to motion. When in the motion viewing mode, the detection zone of video will be displayed in green. Any detected motion within the zone will be displayed in red.

You can define the area of the image where you want to detect motion; e.g., a doorway. Highlight the icon under the **ZONE** heading, and press the  button. The **Motion Detection Zone** screen will display.

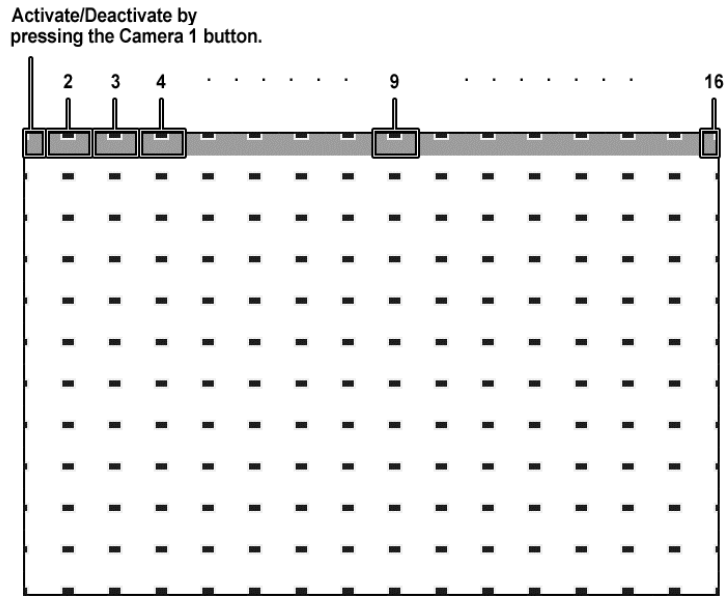



Figure 41 — Motion Detection Zone screen.

The Motion Detection Zone screen is laid over the video for the selected camera. You can set up motion detection zones by selecting or clearing blocks.

NOTE: You can set up motion zones one block at a time in groups of 4, 9 or 16 individual block groups (4-, 9- and 16-channel DVR respectively). A block group is positioned within the image area using the Up and Down arrow buttons, and individual blocks within the block groups are selected or cleared using the camera buttons.

Press the  button to display the menu screen. The menu on the setup screen has the following functions:

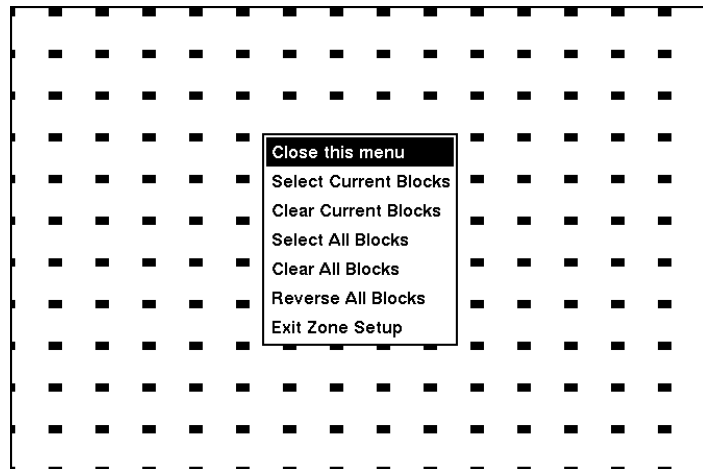

Figure 42 — Motion Detection Zone menu screen.

Close this menu — Closes the menu so that you can see the entire screen.

Select Current Blocks — Activates highlighted blocks to detect motion.

Clear Current Blocks — Deactivates highlighted blocks so that they will not detect motion.

Select All Blocks — Activates all blocks to detect motion.

Clear All Blocks — Deactivates all blocks so that they will not detect motion.

Reverse All Blocks — Activates inactive blocks and deactivates active blocks.

Exit Zone Setup — Asks you to confirm changes and then returns to the previous screen.

Alarm Out Setup Screen

The Alarm Out setup screen allows you to establish a schedule for each alarm output from the DVR.

Alarm Out

| Alarm Out | Title | Sched |
|-----------|-------|-------------------------------------|
| 1 | | <input checked="" type="checkbox"/> |
| 2 | | <input checked="" type="checkbox"/> |
| 3 | | <input checked="" type="checkbox"/> |
| 4 | | <input checked="" type="checkbox"/> |
| Beep | Beep | <input checked="" type="checkbox"/> |

Figure 43 — Alarm Out setup screen.

Each alarm output can be given its own title by highlighting the box under the **Title** heading and pressing the button. A virtual keyboard appears allowing you to enter the title.

Highlighting the **Sched** field and pressing the button opens a schedule screen. You can schedule alarm output in 30-minute increments from 0:00 to 24:00.

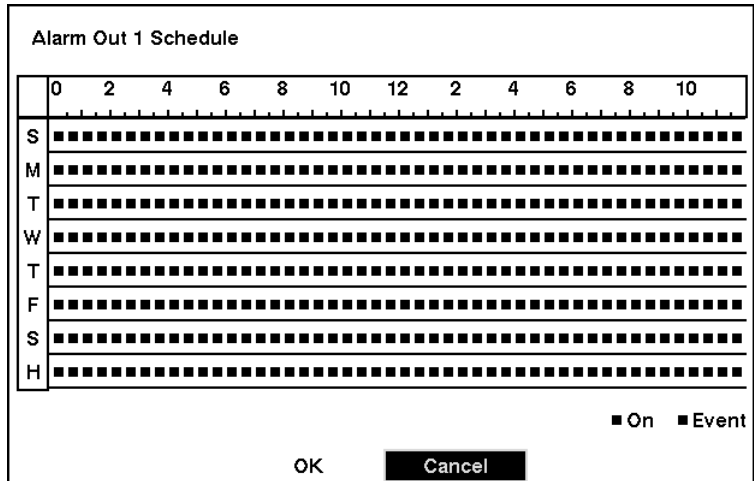



Figure 44 — Alarm Out Schedule screen.

You can select individual blocks of time, entire days of the week, entire blocks of time or the entire schedule. Select a specific block of time by highlighting it. Select an entire day by highlighting the day of the week or Holiday on the left of the screen. Select an entire block of time by highlighting the time at the top of the screen. Select the entire screen by highlighting the empty box in the upper left corner of the screen. Press the button from No Arming (no block) to On (blue block) to Event (yellow block).

When set to On, the Alarm Out is active during the scheduled time. When set to Event, the Alarm Out is only active when there is an Event during the scheduled time.

Audio Setup Screen

Highlight **Audio** in the Main menu and press the  button. The **Audio Setup** screen appears.

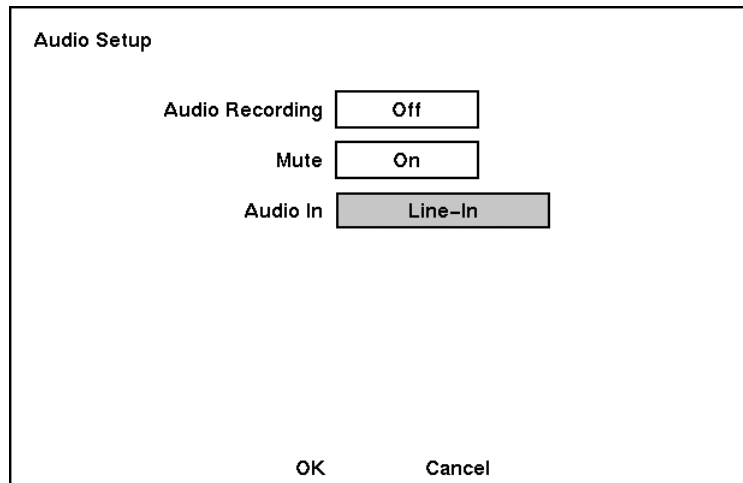





Figure 45 — Audio Setup screen.

Highlight the box beside **Audio Recording** and press the  button. This toggles between **On** and **Off**. When it is **On**, the DVR also records audio when it is recording video.

Highlight the box beside **Mute** and press the  button. This toggles between **On** and **Off**. When it is **On**, the DVR will **NOT** play live or recorded audio.

Highlight the box beside **Audio In** and press the  button. A drop down menu displays the audio inputs. (**Mic In**, **Line In**, and **Observation**).

NOTE: Mic In is for an unamplified source while Line In is for an amplified source.

NOTE: For two-way communication from the DVR to camera locations, select the *Observation*.

You can save your changes by highlighting **OK** and pressing the  button. Selecting **Cancel** exits the screen without saving the changes.

NOTE: If you set up the recording speed less than 1 ips, the DVR will NOT guarantee the standard quality audio playback.

RS232/RS485 Setup Screen

The RS232/RS485 setup screen allows you to set up the RS232 and RS485 ports to communicate with external devices such as remote controls and dome cameras.

| RS232/RS485 | RS232 | RS485 |
|-------------|----------------|----------------|
| Baud Rate | 57600 | 57600 |
| Parity | None | None |
| Data Bit | 8 | 8 |
| Stop Bit | 1 | 1 |
| Usage | External Modem | Remote Control |

OK Cancel

Figure 46 — RS232/RS485 setup screen.

Highlight the field for the settings you wish to make. Select the correct Baud Rate, Parity, Data Bits and Stop Bits for the device you are connecting to the DVR.

For RS232, it is possible to select either Remote Control or External Modem or in the Usage field. For RS485, it is possible to select either Remote Control or PTZ Control in the Usage field.

NOTE: Selecting *External Modem* in the *RS232* field only decides the RS232 port is used for the external modem connections. See *Figure 61 — Modem Setup screen* for details of setting the external modem.

Configuring Recording Settings

NOTE: Pressing the **REC** button on the front of the DVR will cause the red LED to light and indicates the DVR is ready to record. However, this does not mean the DVR is recording. The DVR records video based on the parameters such as schedule and events defined during configuration. The record indicator on the front display panel lights when the DVR is recording.

Your DVR offers a variety of flexible recording modes. You can set it up to record all the time or to only record events. It can be set up to continue recording once the hard disk drive is full by recording over the oldest video, or you can set it up to alert you when the hard disk is full and stop recording.

Record Mode Setup Screen

The image shows a 'Record Mode Setup' screen with the following settings:

| | | |
|-------------------|----------|--------|
| Record Resolution | Standard | |
| End Of Disk | Stop | |
| On Disk Full : | | |
| Beep | Off | |
| Alarm Out | Off | |
| Field Detect | On | |
| Auto Deletion | Off | 1 Day |
| OK | | Cancel |

Figure 47 — Record Mode Setup screen.

Highlight the Record Resolution box and select from High and Standard. All other variables being equal; Selecting High will decrease the recording and playback speed by half than Standard.

Highlight the box beside End Of Disk and press the button. This toggles between Overwrite and Stop. When in the Overwrite mode, the DVR continues recording when the hard disk drive is full by overwriting the oldest video. When in the Stop mode, the DVR stops recording when the hard disk drive is full.

If the DVR is set to the Stop mode, you can set it to beep or activate the Alarm Out AO1 port when the hard disk drive is full. Highlight the box beside On Disk Full: Beep and press the button to toggle between On and Off. Highlight the box beside On Disk Full: Alarm Out and press the button to toggle between On and Off.

The DVR provides the Duplex mode, so you can record and play back video at the same time.

Highlight the box beside Field Detect. Pressing the button toggles between On and Off. When set to On, the Field Detection helps prevent shaking. It does this by recording odd numbered fields from odd numbered cameras and even numbered fields from even numbered cameras.

Highlight the first box beside Auto Deletion. Pressing the button toggles between On and Off. When set to On, the DVR will delete video recorded earlier than user-defined period. Highlight the second box beside Auto Deletion, and press the button to select the length of time recorded data will be kept from 1 to 99 Days.

You can save your changes by highlighting OK and pressing the button. Selecting Cancel exits the screen without saving the changes.

Time-Lapse Record Mode Setup Screen

| Camera | Sched | Mode 1 | | Mode 2 | |
|--------|-------------------------------------|--------|----------|--------|----------|
| | | Speed | Quality | Speed | Quality |
| 1 | <input checked="" type="checkbox"/> | 1 ips | Standard | 1 ips | Standard |
| 2 | <input checked="" type="checkbox"/> | 1 ips | Standard | 1 ips | Standard |
| 3 | <input checked="" type="checkbox"/> | 1 ips | Standard | 1 ips | Standard |
| 4 | <input checked="" type="checkbox"/> | 1 ips | Standard | 1 ips | Standard |

1 - 4 5 - 8 9 - 12 13 - 16

Keep the continuous pictures Off 1 Hour

OK Cancel

Figure 48 — Time-Lapse Record Setup screen.

Highlight the box under the Speed heading and press the button. A drop-down list of record speeds appears. You can select from 1 image per 10 seconds to 60 images per second for NTSC (to 50 images per second PAL).

Highlight the box under the Quality heading and press the button. A drop-down list appears. You can select from Very High, High, Standard and Low image quality. All other variables being equal; Very High will require 600% more hard disk space than Standard, High will require 250% more, and Low 30% less.

NOTE: Higher quality images require more storage space and will reduce the recording capacity of the hard disk drive.

You can set the maximum amount of time-lapse video to be stored. Once the DVR reaches this amount, it will start recording over the oldest time-lapse video. The time lapse video is stored separate from Event video. When **Keep the continuous pictures** is set to On, you can set the time from 1 Hour to the maximum allowed by the storage capacity of your hard disk drive.

NOTE: The maximum storage time is only an estimate because the amount of space required to store video varies depending on many factors such as motion and image complexity.

Time-Lapse Recording Schedule

Camera 1 Recording Schedule

| | 0 | 2 | 4 | 6 | 8 | 10 | 12 | 14 | 16 | 18 | 20 | 22 |
|---|---|---|---|---|---|----|----|----|----|----|----|----|
| S | ■ | ■ | ■ | ■ | ■ | ■ | ■ | ■ | ■ | ■ | ■ | ■ |
| M | ■ | ■ | ■ | ■ | ■ | ■ | ■ | ■ | ■ | ■ | ■ | ■ |
| T | ■ | ■ | ■ | ■ | ■ | ■ | ■ | ■ | ■ | ■ | ■ | ■ |
| W | ■ | ■ | ■ | ■ | ■ | ■ | ■ | ■ | ■ | ■ | ■ | ■ |
| T | ■ | ■ | ■ | ■ | ■ | ■ | ■ | ■ | ■ | ■ | ■ | ■ |
| F | ■ | ■ | ■ | ■ | ■ | ■ | ■ | ■ | ■ | ■ | ■ | ■ |
| S | ■ | ■ | ■ | ■ | ■ | ■ | ■ | ■ | ■ | ■ | ■ | ■ |
| H | ■ | ■ | ■ | ■ | ■ | ■ | ■ | ■ | ■ | ■ | ■ | ■ |

■ Mode 1 ■ Mode 2

OK Cancel

Figure 49 — Time-Lapse Recording Schedule screen.

You can program the DVR to record only during certain times based on time, day of the week, and holidays. The smallest time segment you can use is 30 minutes. A blue rectangle indicates the DVR is set to record during those 30 minutes. When there is no rectangle, the DVR will not record during those 30 minutes.

There are several ways to set recording times:

- You can highlight an individual block and toggle it On or Off by pressing the button.
- You can change a 30-minute segment for all days by placing the cursor on the time line and pressing the button to toggle the segment On or Off.
- You can change an entire day by placing the cursor on the day of the week and pressing the button to toggle the day On or Off.
- You can change the entire calendar by placing the cursor in the upper left-hand box (above “S” and to the left of the time line) and pressing the button to toggle the entire calendar On and Off.

NOTE: The Holiday (H) schedule applies to the dates you established as holidays when setting Date/Time.

You can save your changes by highlighting OK and pressing the  button. Selecting Cancel exits the screen without saving the changes.

Pre-Event Recording Setup Screen

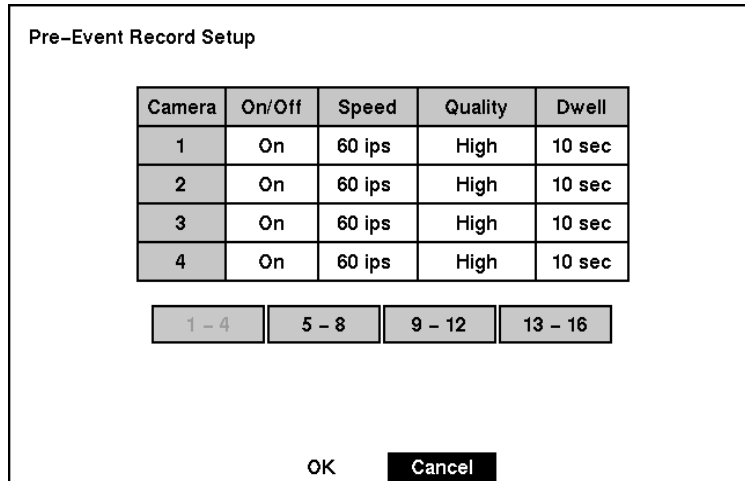

Figure 50 — Pre-Event Record Setup screen.

When the DVR is in the Event Record mode it is possible to have it record images before the event occurs. The Pre-Event Record screen allows you to define how to handle pre-event recording.

You can turn individual cameras On or Off for pre-event recording. The image speed can be set from 0.1 to 60 ips (50 ips PAL), and image quality can be selectable from High, Standard and Low.

You can set the amount of time to record prior to the event by adjusting the Dwell. You can set the Dwell from 1 to 300 seconds.

NOTE: When the DVR is in the Time-Lapse mode, it ignores the pre-event settings and follows the time-lapse settings.

Event Action Setup

Highlight the Alarm In Event Action, Motion Detector Event Action, or Video Loss Event Action in the Event Action menu and press the button. The following Event Action setup screens will appear.

NOTE:

Program event dwell times to expected event periods. Proper dwell time programming will minimize excessive Event Log entries.

DWELL TIME refers to the length of time the DVR will record video and/or annunciate external alarm outputs. The Dwell Time begins and video begins to be recorded at the time of the initial event. Typical events are the alarm-in signal, a detected motion event or a video signal interruption.

For Alarm In Event Action, Motion Detector Event Action, and Video Loss Event Action setup screens, proper use of the event action DWELL time is recommended. The proper use of dwell times will assist in the operation of remote event search functions.

If the programmed dwell times are shorter than the total event time, multiple individual events will be recorded on the hard disk drive and logged in the Event Log. If the dwell time is chosen to closely match the total expected event length, the number of events listed in the Event Log will be reduced.

What happens when the event is longer than the dwell time?

If an event is sixty seconds but has a programmed event dwell time of ten seconds, a total of six (6) individual events will be listed in the Event Log. After the first event begins and the initial ten seconds of dwell time expires, a new event (with an additional ten second dwell time) will be triggered by the event. As a result the Event Log will show six entries that can be viewed individually.

What happens if the event is shorter than the dwell time?

Let's say an event lasts thirty seconds and the dwell time is programmed for sixty seconds. You will get one event in the Event Log, lasting the dwell time limit of sixty seconds.

What happens if the event stops shortly after the dwell time?

Let's say an event is expected to last twenty seconds and the event dwell time is programmed for twenty seconds, and the event exceeds the twenty-second time expectation by only one additional second. Then you will have two events in the event log, each with a twenty-second dwell time.

Proper dwell time programming will minimize excessive Event Log entries and the necessity of multiple event viewing.

Alarm In Event Action (Record) Setup Screen

The DVR can be set to react to events differently. Each sensor can be assigned a schedule, camera, recording speed, video quality and dwell time.

Alarm In Event Action

| | | Mode 1 | Mode 2 | | |
|--------|-------------------------------------|--------|-----------|----------|--------|
| | | Record | Alarm Out | Notify | |
| Sensor | Sched | Camera | Speed | Quality | Dwell |
| 1 | <input checked="" type="checkbox"/> | 1 | 60 ips | Standard | 10 sec |
| 2 | <input checked="" type="checkbox"/> | 2 | 60 ips | Standard | 10 sec |
| 3 | <input checked="" type="checkbox"/> | 3 | 60 ips | Standard | 10 sec |
| 4 | <input checked="" type="checkbox"/> | 4 | 60 ips | Standard | 10 sec |

1 - 4 5 - 8 9 - 12 13 - 16

OK Cancel

Figure 51 — Alarm In Event Action (Record) setup screen.

Highlight the Sched box and press the button. A schedule screen appears. Set the schedule as described earlier.

Highlight the Camera box and press the button. A camera selection screen appears. Select the camera number you would like to associate with the sensor.

NOTE: You can associate multiple cameras with a sensor.

Highlight the Speed box and select number of images per second you would like to record from the drop-down menu.

Highlight the Quality box and select the image quality you want to record from the drop-down menu.

Highlight the Dwell box and set the length of time you would like to record for the associated event.

Alarm In Event Action (Alarm Out) Setup Screen

The DVR can be set to react to events differently by activating an internal buzzer or external alarms.

Alarm In Event Action

| | | Mode 1 | Mode 2 |
|--------|-------------------------------------|-----------|-----------|
| | | Record | Alarm Out |
| Sensor | Sched | Alarm Out | Dwell |
| 1 | <input checked="" type="checkbox"/> | - | 10 sec |
| 2 | <input checked="" type="checkbox"/> | - | 10 sec |
| 3 | <input checked="" type="checkbox"/> | - | 10 sec |
| 4 | <input checked="" type="checkbox"/> | - | 10 sec |

1 - 4 5 - 8 9 - 12 13 - 16

OK Cancel

Figure 52 — Alarm In Event Action (Alarm Out) setup screen.

Highlight the Sched box and press the button. A schedule screen appears. Set the schedule as described earlier.

Highlight the Alarm-Out box and either Beep or the alarm output terminal that you want to associate with the sensor.

Highlight the Dwell box and set the length of time you want the output activated.

NOTE: When setting the *Dwell* to “0 sec”, the alarm output will be activated throughout the sensor activation period, and inactive while the sensor is inactive.

Alarm In Event Action (Notify) Setup Screen

The DVR can be set to notify the remote site when certain events are activated.

Alarm In Event Action

| | | | |
|--|--|--------|-----------|
| | | Mode 1 | Mode 2 |
| | | Record | Alarm Out |
| | | Notify | |

| Sensor | Sched | Notify |
|--------|-------------------------------------|--------|
| 1 | <input checked="" type="checkbox"/> | Off |
| 2 | <input checked="" type="checkbox"/> | Off |
| 3 | <input checked="" type="checkbox"/> | Off |
| 4 | <input checked="" type="checkbox"/> | Off |

| | | | |
|-------|-------|--------|---------|
| 1 - 4 | 5 - 8 | 9 - 12 | 13 - 16 |
|-------|-------|--------|---------|

| | |
|----|--------|
| OK | Cancel |
|----|--------|

Figure 53 — Alarm In Event Action (Notify) setup screen.

Highlight the Sched box and press the button. A schedule screen appears. Set the schedule as described earlier.

Highlight the Notify box and press the button. This toggles between On and Off. When it is On, the DVR notifies the remote site when certain events occur based on a defined schedule.

Motion Detector Event Action (Record) Setup Screen

The DVR can be set to react to motion detector differently. Each camera can be assigned a schedule, associated camera, recording speed, video quality and dwell time.

Motion Detector Event Action

| | | Mode 1 | Mode 2 | | |
|--------|-------------------------------------|--------|-----------|----------|--------|
| | | Record | Alarm Out | Notify | |
| Camera | Sched | Camera | Speed | Quality | Dwell |
| 1 | <input checked="" type="checkbox"/> | 1 | 60 ips | Standard | 10 sec |
| 2 | <input checked="" type="checkbox"/> | 2 | 60 ips | Standard | 10 sec |
| 3 | <input checked="" type="checkbox"/> | 3 | 60 ips | Standard | 10 sec |
| 4 | <input checked="" type="checkbox"/> | 4 | 60 ips | Standard | 10 sec |

1 - 4 5 - 8 9 - 12 13 - 16

OK Cancel

Figure 54 — Motion Detector Event Action (Record) setup screen.

Highlight the Sched box and press the button. A schedule screen appears. Set the schedule as described earlier.

Highlight the Camera box and press the button. A camera selection screen appears. Select the camera number you would like to associate with the camera.

NOTE: You can associate multiple cameras with a camera that detects motion.

Highlight the Speed box and select number of images per second you would like to record from the drop-down menu.

Highlight the Quality box and select the image quality you want to record from the drop-down menu.

Highlight the Dwell box and set the length of time you would like to record for the associated motion event.

Motion Detector Event Action (Alarm Out) Setup Screen

The DVR can be set to react to motion events differently by activating an internal buzzer or external alarms.

Motion Detector Event Action

| | | Mode 1 | Mode 2 |
|--------|-------------------------------------|-----------|-----------|
| | | Record | Alarm Out |
| Camera | Sched | Alarm Out | Dwell |
| 1 | <input checked="" type="checkbox"/> | - | 10 sec |
| 2 | <input checked="" type="checkbox"/> | - | 10 sec |
| 3 | <input checked="" type="checkbox"/> | - | 10 sec |
| 4 | <input checked="" type="checkbox"/> | - | 10 sec |

1 - 4 5 - 8 9 - 12 13 - 16

OK Cancel

Figure 55 — Motion Detector Event Action (Alarm Out) setup screen.

Highlight the Sched box and press the button. A schedule screen appears. Set the schedule as described earlier.

Highlight the Alarm-Out box and either Beep or the alarm output terminal that you want to associate with the motion event.

Highlight the Dwell box and set the length of time you want the output activated.

NOTE: When setting the *Dwell* to “0 sec”, the alarm output will be activated throughout the sensor activation period, and inactive while the sensor is inactive.

Motion Detector Event Action (Notify) Setup Screen

The DVR can be set to notify the remote site when certain motion events are activated.

Motion Detector Event Action

| | | Mode 1 | Mode 2 |
|--------|-------------------------------------|--------|-----------|
| | | Record | Alarm Out |
| Camera | Sched | Notify | |
| 1 | <input checked="" type="checkbox"/> | Off | |
| 2 | <input checked="" type="checkbox"/> | Off | |
| 3 | <input checked="" type="checkbox"/> | Off | |
| 4 | <input checked="" type="checkbox"/> | Off | |

1 - 4 5 - 8 9 - 12 13 - 16

OK Cancel

Figure 56 — Motion Detector Event Action (Notify) setup screen.

Highlight the Sched box and press the button. A schedule screen appears. Set the schedule as described earlier.

Highlight the Notify box and press the button. This toggles between On and Off. When it is On, the DVR notifies the remote site when certain events occur based on a defined schedule.

Video Loss Event Action (Record) Setup Screen

The DVR can be set to react to video loss from a camera differently. Each camera can be assigned a schedule, associated camera, recording speed, video quality and dwell time.

| Video Loss Event Action | | | | | |
|-------------------------|-------------------------------------|--------|-----------|----------|--------|
| | | Mode 1 | Mode 2 | | |
| | | Record | Alarm Out | Notify | |
| Camera | Sched | Camera | Speed | Quality | Dwell |
| 1 | <input checked="" type="checkbox"/> | - | 60 ips | Standard | 10 sec |
| 2 | <input checked="" type="checkbox"/> | - | 60 ips | Standard | 10 sec |
| 3 | <input checked="" type="checkbox"/> | - | 60 ips | Standard | 10 sec |
| 4 | <input checked="" type="checkbox"/> | - | 60 ips | Standard | 10 sec |

| | | | |
|-------|-------|--------|---------|
| 1 - 4 | 5 - 8 | 9 - 12 | 13 - 16 |
|-------|-------|--------|---------|

OK **Cancel**

Figure 57 — Video Loss Event Action (Record) setup screen.

Highlight the **Sched** box and press the button. A schedule screen appears. Set the schedule as described earlier.

Highlight the **Camera** box and press the button. A camera selection screen appears. Select the camera number you would like to associate with the camera that has lost video.

NOTE: You can associate multiple cameras with a camera.

Highlight the **Speed** box and select number of images per second you would like to record from the drop-down menu.

Highlight the **Quality** box and select the image quality you want to record from the drop-down menu.

Highlight the **Dwell** box and set the length of time you would like to record for the associated video loss.

Video Loss Event Action (Alarm Out) Setup Screen

The DVR can be set to react to video loss differently by activating an internal buzzer or external alarms.

Video Loss Event Action

| | | Mode 1 | Mode 2 |
|--------|-------------------------------------|-----------|-----------|
| | | Record | Alarm Out |
| | | | Notify |
| Camera | Sched | Alarm Out | |
| 1 | <input checked="" type="checkbox"/> | Beep | |
| 2 | <input checked="" type="checkbox"/> | Beep | |
| 3 | <input checked="" type="checkbox"/> | Beep | |
| 4 | <input checked="" type="checkbox"/> | Beep | |

1 - 4 5 - 8 9 - 12 13 - 16

OK **Cancel**

Figure 58 — Video Loss Event Action (Alarm Out) setup screen.

Highlight the Sched box and press the button. A schedule screen appears. Set the schedule as described earlier.

Highlight the Alarm-Out box and either Beep or the alarm output terminal that you want to associate with the camera that has lost video.

Video Loss Event Action (Notify) Setup Screen

The DVR can be set to notify the remote site in the case of video loss.

Video Loss Event Action

| | | |
|--------|-----------|--------|
| Mode 1 | Mode 2 | |
| Record | Alarm Out | Notify |

| Camera | Sched | Notify |
|--------|-------------------------------------|--------|
| 1 | <input checked="" type="checkbox"/> | Off |
| 2 | <input checked="" type="checkbox"/> | Off |
| 3 | <input checked="" type="checkbox"/> | Off |
| 4 | <input checked="" type="checkbox"/> | Off |

| | | | |
|-------|-------|--------|---------|
| 1 - 4 | 5 - 8 | 9 - 12 | 13 - 16 |
|-------|-------|--------|---------|

OK
Cancel

Figure 59 — Video Loss Event Action (Notify) setup screen.

Highlight the **Sched** box and press the button. A schedule screen appears. Set the schedule as described earlier.

Highlight the **Notify** box and press the button. This toggles between **On** and **Off**. When it is **On**, the DVR notifies the remote site when it loses video input from a camera based on a defined schedule.

Display Setup

Highlight the OSD, Main Monitoring, or Spot Monitoring in the Main menu, and press the button to set up the on-screen display, or camera display on the main monitor or spot monitor.

OSD (On-Screen Display) Setup

The DVR can be set up to display Date, Time, Title and Status on screen. Each feature can be turned on or off, and you can adjust the margins.

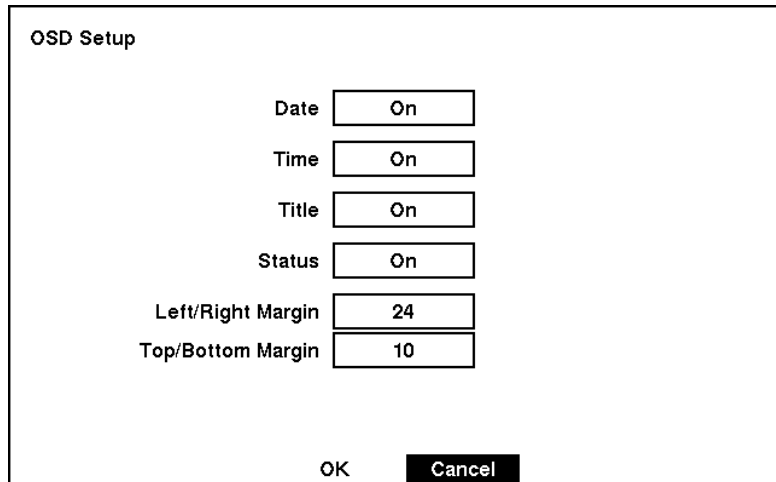

The image shows a screenshot of the 'OSD Setup' screen. It contains several settings, each with a label and a corresponding input box. The settings are: Date (On), Time (On), Title (On), Status (On), Left/Right Margin (24), and Top/Bottom Margin (10). At the bottom of the screen, there are two buttons: 'OK' and 'Cancel'.

| Setting | Value |
|-------------------|-------|
| Date | On |
| Time | On |
| Title | On |
| Status | On |
| Left/Right Margin | 24 |
| Top/Bottom Margin | 10 |

Figure 60 — OSD Setup screen.

Highlight the box beside **Date** and press the button to toggle the date display On and Off.

Highlight the box beside **Time** and press the button to toggle the time display On and Off.

Highlight the box beside **Title** and press the button to toggle the camera title display On and Off.

Highlight the box beside **Status** and press the button to toggle status display On and Off.

Highlight the box beside **Left/Right Margin** and press the button to adjust the left and right margins. The margins can be set from 1 to 24.

Highlight the box beside **Top/Bottom Margin** and press the button to adjust the top and bottom margins. The margins can be set from 1 to 24.

Main Monitoring Setup Screen

You can adjust the display dwell time for each camera displayed on the main monitor. You can also turn camera sequence and event monitoring on and off.

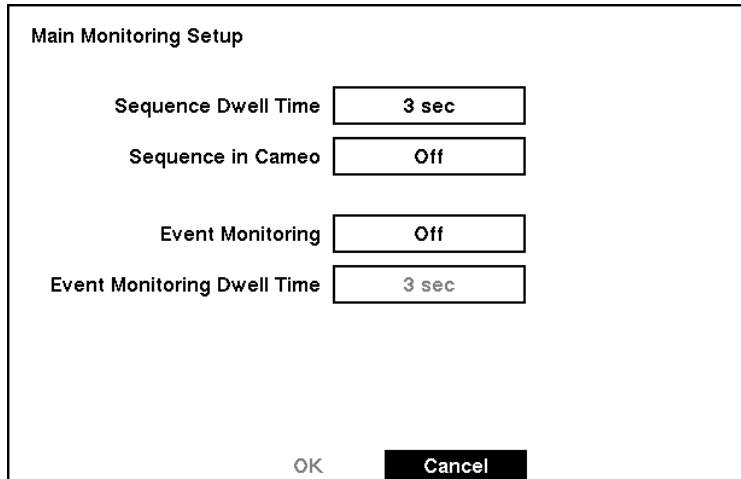

The image shows a 'Main Monitoring Setup' dialog box with the following settings:

| | |
|-----------------------------|-------|
| Sequence Dwell Time | 3 sec |
| Sequence in Cameo | Off |
| Event Monitoring | Off |
| Event Monitoring Dwell Time | 3 sec |

At the bottom, there are 'OK' and 'Cancel' buttons.

Figure 61 — Main Monitoring Setup screen.

Highlight the box beside **Sequence Dwell Time** and press the button. You can adjust the sequence dwell time from 3 to 60 seconds.

Highlight the box beside **Sequence in Cameo** and press the button to toggle between On and Off. (Not on 4-camera model.)

Pressing the **SEQUENCE** button causes the DVR to sequence cameras, and the DVR can sequence cameras in two modes: “Page” and “Cameo”. In the Page mode, the DVR sequences through user-defined screen layouts (pages). In the Cameo mode, the bottom right window in a multi-screen format sequences through all cameras.

NOTE: The DVR does not sequence the camera having video loss in the Cameo mode.

You can define the screen layout in a variety of formats and set the DVR to sequence through the different screen layouts (pages) so that all the cameras will be displayed. You can also set up the DVR to display one camera or a group of cameras all the time while cycling through the remaining cameras in a “cameo” window. This can be done with one camera displayed full screen while displaying the cameo window as a PIP (picture in picture), or displaying the cameras in a grid pattern with the bottom right window as the cameo.

NOTE: Sequence cannot be used in the 4x4 display mode of the 16-channel, 3x3 mode of the 9-channel and the 2x2 mode of the 4-channel DVR.

Highlight the box beside **Event Monitoring** and press the button to toggle between **On** and **Off**. When **On**, video from the lowest camera number among those associated with the event-detected sensor will be displayed full-screen on the monitor for the preset dwell time.

Highlight the box beside **Event Monitoring Dwell Time** and press the button. You can adjust the event monitoring dwell time from 3 to 60 seconds.

Spot Monitoring Setup Screen

You can adjust the display dwell time for each camera displayed on the spot monitor. You can also turn event monitoring on and off.

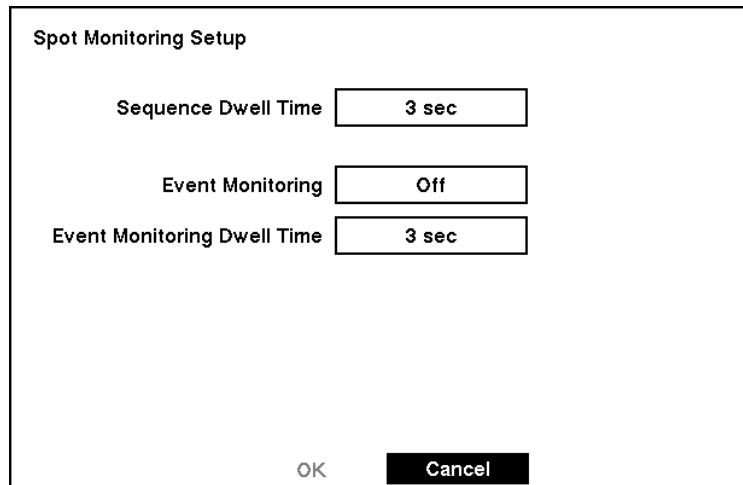

The image shows a 'Spot Monitoring Setup' screen with three rows of settings, each with a label and a value in a box:

- Sequence Dwell Time: 3 sec
- Event Monitoring: Off
- Event Monitoring Dwell Time: 3 sec

At the bottom, there are two buttons: 'OK' and 'Cancel'.

Figure 62 — Spot Monitoring Setup screen.

Highlight the box beside **Sequence Dwell Time** and press the button. You can adjust the sequence dwell time from 3 to 60 seconds.

Highlight the box beside **Event Monitoring** and press the button to toggle between **On** and **Off**. When it is **On**, the video of the lowest camera number among cameras associated with the event-detected sensor will be displayed in full-screen on the spot monitor during the preset dwell time.

Highlight the box beside **Event Monitoring Dwell Time** and press the button. You can adjust the event monitoring dwell time from 3 to 60 seconds.

Network Setup Screen

In the Network Setup screen you can set up the DVR for LAN connections.

The screenshot shows a 'Network Setup' window with the following fields and values:

| | | |
|------------------|----------|----------|
| Connection | LAN | Setup... |
| Admin Password | ***** | |
| User Password | ***** | |
| Transfer Control | Off | |
| Transfer Speed | 10 ips | |
| Remote Quality | Standard | |

At the bottom of the window are 'OK' and 'Cancel' buttons.

Figure 63 — Network Setup screen.

Highlight the box beside **Connection**. Press the button to toggle between LAN and Modem.

Highlight the box beside **Admin Password** and press the button. A virtual keyboard appears. You will first be asked to enter the current password. Then you can enter a new password; you will be asked to confirm the new password before it is accepted.

Highlight the box beside **User Password** and press the button. A virtual keyboard appears. You will first be asked to enter the current password. Then you can enter a new password; you will be asked to confirm the new password before it is accepted.

NOTE: These passwords are for network use. They are different from the Admin and User passwords for the DVR itself.

NOTE: The passwords are case sensitive. The factory default password for both Administrator and User is **12345678**.

CAUTION: Write the password down and keep it in a safe place. Once the password has been reset, the default will no longer work. If the password is forgotten, the unit must be reset using the **Factory Reset Button** and all data settings will be lost.

Highlight the box beside **Transfer Control**. Press the button to toggle between On and Off. When it is On, you can set the transfer speed and remote quality of the image transferred to a computer running RAS (Remote Administration System).

Highlight the box beside Transfer Speed and press the button. Select the transfer speed from 1 to 30 ips.

NOTE: The transfer speed you set is the maximum speed, so this speed cannot be achieved according to the network environment.

NOTE: The transfer speed indicates the number of images which transferred to each RAS. If two remote sites (RAS) are connecting to the DVR, the number of images transferred via network will be 'Transfer Speed x 2'.

NOTE: The Transfer Control option will affect DVR's recording performance. The DVR has a maximum recording speed of 60 NTSC images per second (50 PAL images per second). The number of remote site (RAS) connected to the DVR does not affect the recording speed. It will be affected by only Transfer Speed. The local recording speed will not be affected if the DVR is not connected remotely.

NOTE: If the Transfer Control is not used, the speed of data transfer to remote site will be same as the local recording speed.

Highlight the box beside Remote Quality and press the button. Select the image quality from Very High, High, Standard and Low.

LAN Setup Screen

| LAN Setup | |
|-------------------------------|---------------|
| IP Address | 192.168.1.129 |
| Gateway | 192.168.1.254 |
| Subnet Mask | 255.255.255.0 |
| IP Port Number (8000 ~ 12000) | |
| Admin | 8200 |
| Watch | 8016 |
| Search | 10019 |
| Callback | 8201 |
| OK | Cancel |

Figure 64 — LAN Setup screen.

NOTE: You will need to get the appropriate IP Address, Gateway, Subnet Mask and IP Port Number for each RAS related program (Admin, Watch, Search and Callback) from your network administrator.

Change the numbers by highlighting them and using the Up and Down arrow buttons to increase or decrease the number.

The factory default LAN settings are:

IP Address: 192.168.1.129
Gateway: 192.168.1.254
Subnet Mask: 255.255.255.0

The factory default IP Port settings are:

Admin: 8200
Watch: 8016
Search: 10019
Callback: 8201

NOTE: Do NOT use the same IP port number for two different programs, otherwise, the DVR cannot be connected with a PC running RAS.

CAUTION: When changing the IP port settings, you must change the IP port settings on a PC running RAS as well. Refer to the RAS manual for details.

You can save your changes and return to the Network Setup screen by highlighting OK and pressing the button. Selecting Cancel exits the screen without saving the changes.

Modem Setup

| | |
|-----------|----------------|
| Use | Internal Modem |
| Baud Rate | 57600 |
| Data Bit | 8 |
| Stop Bit | 1 |
| Parity | None |

OK Cancel

Figure 65 — Modem Setup screen.

Highlight the box beside Use and press the button. This toggles between Internal Modem and External Modem.

Highlight **Baud Rate** and press the button. A list of baud rates ranging from 300 to 115,200 appears.

Highlight the box beside **Data Bit** and press the button. This toggles between 7 bit and 8 bit formats.

Highlight the box beside **Stop Bit** and press the button. This toggles between 1 and 2 Stop Bits.

Highlight the box beside **Parity** and press the button. A drop-down list appears. You can select from **None**, **Odd** or **Even** parity.

You can save your changes by highlighting **OK** and pressing the button. Selecting **Cancel** exits the screen without saving the changes.

NOTE: An internal modem may have compatibility problem with the modem used for the RAS (Remote Administration System). Please contact your dealer/installer for available models for the RAS.

Callback Center Setup Screen

| Callback Center Setup | |
|-----------------------|----------------|
| IP Address | 192.168.1.10 |
| Retry | 3 |
| ----- | |
| Device | Internal Modem |
| Pager Number | |
| Mailbox | |
| Site ID | 1 |
| OK | Cancel |

Figure 66 — Callback Center Setup screen.

The DVR can be set up to contact a computer running RAS (Remote Administration System) on a LAN when an event occurs. Also it can be set up to dial a pager with a numeric message when an event occurs if you have a modem connected to the DVR.

NOTE: When the DVR is networked with LAN connections, you can set up the callback center by both LAN connections and modem connections.

Callback Center Setup by LAN connections

Highlight the box beside **IP Address** and enter the IP address of the computer you want contacted during an event.

Highlight the box beside **Retry** and enter the number of times you would like the DVR to try contacting the computer. You can select from 1 to 10 retries.

Callback Center Setup by Modem connections

Highlight the box beside **Device** and press the button. Select **Internal Modem**, **External Modem** or **None** from a drop-down menu.

Highlight the box beside **Pager Number** and enter the telephone number of the pager. Enter the number as it must be dialed from your telephone system; e.g., if you must dial "9" for an outside line, enter "9" before the pager number.

Highlight the box beside **Mailbox** and enter the voice mailbox number if your pager uses a voice mailbox.

Highlight the box beside **Site ID** and enter a three-digit site ID number.

When an event occurs, the DVR will dial the pager and leave a four-digit number. The first three digits are the site ID number and the last digit is the type of event (1: Alarm In, 2: Motion Detection, 3: Video Loss and 10: Storage). For example, "0753" means that Site 75 has lost video.

NOTE: The DVR will wait for at least four minutes between pages. If another event occurs less than four minute after the DVR has notified a pager, it will not dial the pager. It does this so that the telephone line will not be tied up.

You can save your changes by highlighting **OK** and pressing the button. Selecting **Cancel** exits the screen without saving the changes.

Password Setup Screen

An Administrator password is required to turn the system off, enter the setup screen, load default setups, clear all data, change system date and time and change the Administrator password. A User password is required to enter playback, fast forward playback and fast backward playback modes from live monitoring mode, enter the search menu screen in live monitoring mode, and press the button to display the event log in live monitoring mode unless there is an active alarm. Highlight **Password** in the Main menu and press to enter the **Password** screen.

Password

| Permission | On/Off | Password |
|-------------|--------|----------|
| User | On | ***** |
| Admin Setup | | ***** |

Key Lock On

OK Cancel

Figure 67 — Password setup screen.

Highlight the box beside **User** and press the button to toggle between **On** and **Off**. If the password is set to **On**, you will be asked to enter the current password so that you can turn it **Off**. If the password is set to **Off**, you will be asked to enter the new password and to confirm it before it will be turned on.

The Administrator password cannot be turned **On** and **Off**. You can change the Administrator password by first entering the current password, entering a new password and finally confirming the new password.

To change the password, highlight the **Password** box and press the button. A window appears asking you to enter the current password. If you enter the correct password, another window appears asking you to enter a new password using the camera buttons. After you press the button, another screen appears asking you to confirm the new password.

NOTE: The Admin and User passwords are composed of up to eight digits using the camera buttons. The default User password is **1234**, and Admin password is **4321**.

CAUTION: Write down the new password and save it in a secure place. If the password is forgotten, the unit must be reset using the **Factory Reset Button** and all data settings will be lost.

To lock front panel buttons, highlight **Key Lock On** and press the button. Once the buttons are locked, pressing any front panel button will cause a password screen to display. You will need to enter the correct password to unlock the keys. The Key Lock password is **4231**. The Administrator password also can be used to unlock the keys.

You can save your changes by highlighting **OK** and pressing button. Selecting **Cancel** exits the screen without saving the changes.

Config Screen

The Config menu is used to perform functions such as switching between Quick Setup and Normal Setup, archiving and backing up video, loading default setup and clearing all data.

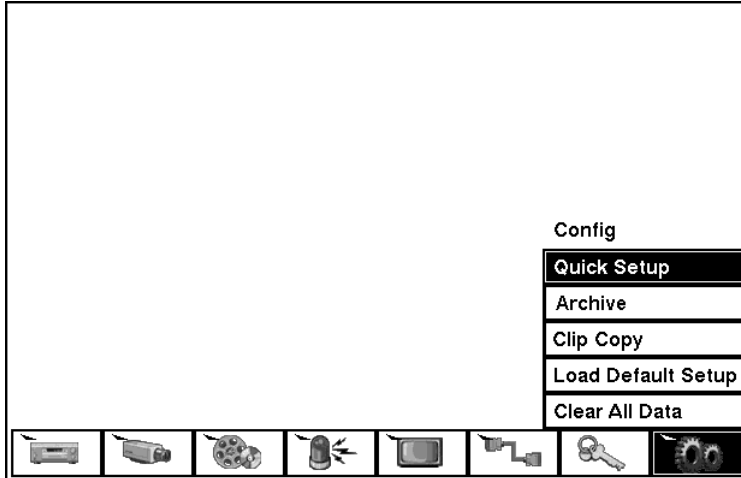

Figure 68 — Config screen.

Archive

The Archive screen can be used to archive video automatically or manually.

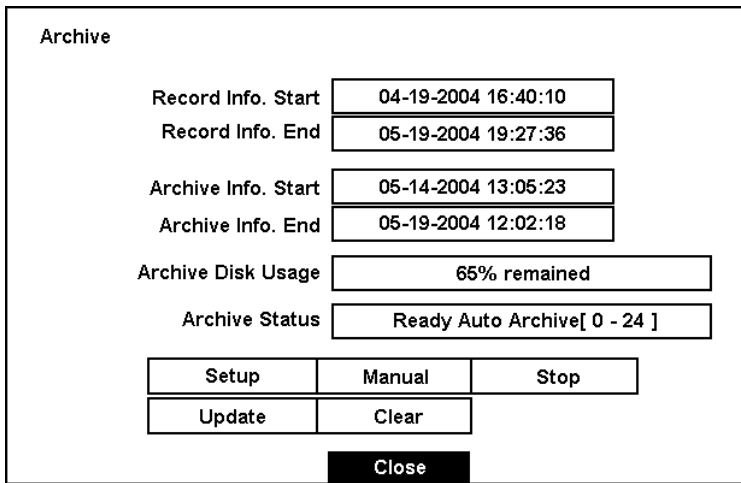
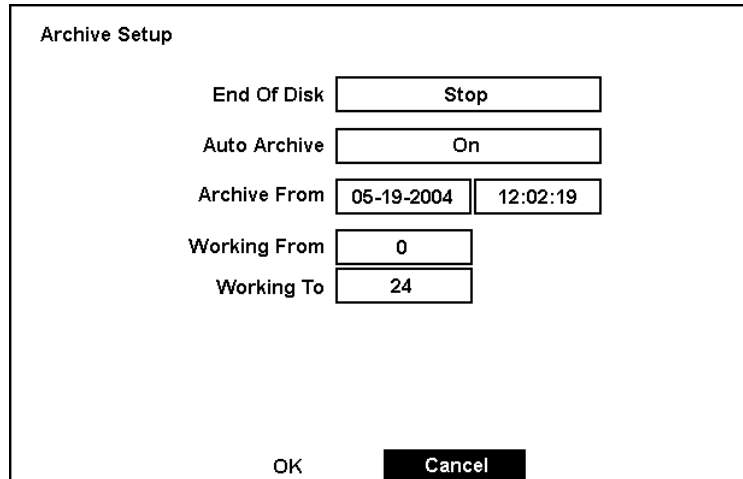

Figure 69 — Archive screen.

Selecting **Update** loads the latest information displayed on the **Archive** screen.

Selecting **Clear** erases all archived data.

Selecting **Setup** displays a screen where you set up archive parameters.



The screenshot shows the 'Archive Setup' screen with the following settings:

| | | |
|--------------|------------|----------|
| End Of Disk | Stop | |
| Auto Archive | On | |
| Archive From | 05-19-2004 | 12:02:19 |
| Working From | 0 | |
| Working To | 24 | |

At the bottom of the screen, there are two buttons: 'OK' and 'Cancel'.

Figure 70 — Archive Setup screen.

Highlight the box beside **End Of Disk** and press the button. This toggles between **Overwrite** and **Stop**. When set to **Overwrite**, the DVR continues archiving when the device drive is full by overwriting the oldest video. When set to **Stop**, the DVR stops archiving when the device drive is full.

Highlight the box beside **Auto Archive** and press the button. This toggles between **On** and **Off**. When it is **On**, the DVR will archive video automatically from the time set on the **Archive From** field.

Highlight the box beside **Archive From** and press the button to set up the archive start date and time.

Highlight the box beside **Working From / Working To** and press the button to set up the time span of the automatic archive.

You can save your changes by highlighting **OK** and pressing button. Selecting **Cancel** exits the screen without saving the changes.

Selecting **Manual** displays a screen where you set up manual archive parameters.

| Manual Archive | |
|---|---------------------|
| Record Info. Start | 04-19-2004 16:40:10 |
| Record Info. End | 05-19-2004 19:27:36 |
| Archive Info. Start | 05-14-2004 13:05:23 |
| Archive Info. End | 05-19-2004 12:02:18 |
| Archive Disk Usage | 65% remained |
| From | 05-14-2004 13:05:23 |
| To | 05-14-2004 13:05:23 |
| Archive Now <input type="button" value="Cancel"/> | |

Figure 71 — Manual Archive screen.

Highlight the boxes beside From and To and press the button to set up the archive start and stop times and dates.

Once you set the archive start and stop times and dates, highlight the Archive Now button and press the button.

You can end the archiving process at any time by highlighting the Stop button and pressing the button.

NOTE: The Stop button will display only during archiving.

NOTE: If you have a large quantity of recorded video to archive, either stop recording or reset the recording speed. The oldest data to be archived might be overwritten if the hard disk is full.

Clip Copy

The Clip Copy screen can be used to back up video to an internal CD-RW drive, or external USB hard disk drive or CD-RW drive. The backup clip images can be viewed on computers running Microsoft Windows 98, ME, 2000 or XP. Refer to the *Appendix A — USB Hard Disk Drive Preparation* for information on preparing the external drive for back up.

| Clip Copy | | | |
|-----------|---|-----------------------------|---|
| | Local | USB HDD | <input checked="" type="checkbox"/> Audio |
| From | <input checked="" type="checkbox"/> First | 05-19-2004 | 00:45:06 |
| To | <input checked="" type="checkbox"/> Last | 05-19-2004 | 00:45:06 |
| Camera | <input type="checkbox"/> 1 | <input type="checkbox"/> 2 | <input type="checkbox"/> 3 |
| | <input type="checkbox"/> 5 | <input type="checkbox"/> 6 | <input type="checkbox"/> 7 |
| | <input type="checkbox"/> 9 | <input type="checkbox"/> 10 | <input type="checkbox"/> 11 |
| | <input type="checkbox"/> 13 | <input type="checkbox"/> 14 | <input type="checkbox"/> 15 |
| | <input type="checkbox"/> 4 | <input type="checkbox"/> 8 | <input type="checkbox"/> 12 |
| | <input type="checkbox"/> 16 | | |
| File Name | <input type="text"/> | | |
| | Start | Close | |

Figure 72 — Clip Copy screen.

To select the data source to back up, highlight the first box on the top and press the button. A drop-down list of available data source appears. You can select from Local or Archive.

To select the type of the drive to use for clip copy, highlight the second box on the top and press the button. A drop-down list of available drives appears. You can select from IDE CD-RW, USB HDD or USB CD-RW.

Placing a checkmark in the Audio box archives recorded audio with video.

NOTE: It is possible to use the USB CD-RW drive for clip copy when less than three SCSI hard disk drives are connected to the DVR, and use the IDE CD-RW drive when less than four SCSI hard disk drives are connected.

NOTE: A CD-R or CD-RW disk that was written to using a computer might not work in a USB CD-RW drive connected to the DVR.

You can define how much video to back up by changing the start and end times and dates. You can also select which camera you wish to back up.

Highlight the File Name box and press the button. A virtual keyboard appears. Enter a file name for the video you are backing up and select Close. The DVR will automatically add the camera number (for example “01”) and “.exe” to the file name. If you want to save the file in a specific folder, enter the folder name followed by a “/”. For example: “folder/filename”

Once you have given the video a file name, highlight the Start button and press the button. The DVR will display the drive capacity, the backup file size and ask if you want to continue.

NOTE: Do not back up files larger than 2GB.

You can use other functions on the DVR while video is being backed up. To do this, highlight the **CLOSE** button and press the  button. You can return to the **Clip Copy** screen at any time to check the progress.

NOTE: You can not end the archiving process during CD burning.

Refer to *Appendix B — Reviewing Backup (Clip) Images* for instructions on how to review the images you have backed up.

NOTE: During clip copy, you cannot change the system date and time, shut the system down, switch to the Quick Setup mode, clear all data, and change the system setup from a remote site.

CAUTION: Do NOT disconnect the USB cable or the power from the external drive while backing up video. If the external drive is shut down or the USB cable is disconnected while backing up, THE DVR SYSTEM MAY NOT WORK NORMALLY OR THE EXTERNAL DRIVE COULD BE DAMAGED, and you will get an error message the next time you try to back up. You will need to power down the DVR and restart it to get rid of the error message. Once the file system of the USB-IDE hard disk drive has been corrupted, this error message cannot be dismissed. Even after restarting the DVR it may automatically restart while preparing a backup. You must recover the file system using the recovery program, or you must reformat the hard disk drive.

Load Default Setup

Highlighting and selecting **Load Default Setup** will bring up a screen asking you if you really want to load default settings and confirm it with a password.

NOTE: Loading the Default Setup will not change the current time, time zone, daylight saving time and network settings.

Clear All Data

Highlighting and selecting **Clear All Data** will bring up a screen asking you if you really want to clear all data and confirm it with a password.

CAUTION: Selecting *Clear All Data* will erase all recorded video.

Chapter 4 — Operation

NOTE: This chapter assumes your DVR has been installed and configured. If it has not, please refer to Chapters 2 and 3.

The DVR's controls are similar to a VCR. As with a VCR, the main functions are recording and playing back video. However, you have much greater control over recording and playing back video. You can establish recording schedules based on time of day and day of the week. The DVR allows you to search through the recorded video using much more sophisticated tools than those available with VCRs. Additional DVR features that are not available with VCRs are remote control and viewing, recording video at the same time you are watching previously recorded video, and printing images to a standard printer.

The Front Panel Display and controls are described in *Chapter 3 — Configuration*.

Turning on the Power

Once you have installed the DVR following the instructions in *Chapter 2 — Installation*, it is ready to record.

The unit will take approximately 60 seconds to initialize. While it is initializing, the DVR will display HELLO. Then, the HELLO will start moving to the left.

Live Monitoring

As soon as the DVR completes its initialization process, it will begin showing live video on the attached monitor and playing live audio through the attached speaker. The default mode is to display all cameras at once. Pressing any camera button will cause that camera to display full screen. It displays live video and plays live audio until the user enters another mode.

Pressing the **DISPLAY** button cycles the DVR through the different display formats.

The DVR can be set to display the event-detected video in full-screen on the monitor during the preset dwell time when there is an Event. The video of the lowest camera number among cameras associated with the event-detected sensor will be displayed, the DVR will return to the previous screen format after event monitoring dwell time. While the event monitoring is activated, the monitoring for all other subsequent events will be ignored. Pressing the individual camera button or the **DISPLAY** button during event monitoring releases the current event monitoring and displays the selected camera or return to the previous screen format.

Pressing the **SEQUENCE** button will cause the cameras to display sequentially on the monitor. When in one of the multi-view formats, pressing this button will cause the DVR to through user-defined screen layouts (page sequence), or the bottom, right screen to display live cameras sequentially (cameo sequence). Selecting another display mode, or pressing the **SEQUENCE** button again will exit the Sequence mode. When in one of the multi-view formats, pressing the **Left** or **Right** arrow buttons will cause the DVR to go to the previous or the next page. For example, if you press the **Right** arrow button in 4x4 format, the DVR changes the page like that.

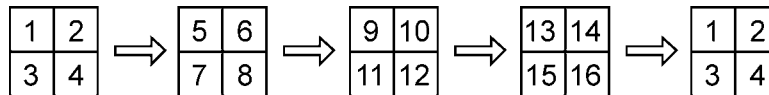

For the sequence display on the spot monitor, press the **SPOT** button and then **SEQUENCE** button.

Pressing the **FREEZE** button will freeze the current image on the screen until you press the button again.

Active Cameo Mode

You can enter the Active Cameo mode by pressing the **⇐** button in any multi-view format. The gray-highlight box at the bottom of video indicates the active cameo, and pressing the arrow buttons moves the active cameo. Pressing the **⇐** button while in the Active Cameo mode exits the Active Cameo mode. The active cameo mode will keep up 15 seconds if there is no consequent operation.

In active cameo mode, press the camera button you want to show that video at active cameo. After setting the camera number at active cameo, the DVR moves the active cameo to the next cameo. You can change the screen layout in this way.

The active cameo also can be used to select the camera to control Pan, Tilt and Zoom capabilities and select the audio channel to communicate. If you want to select the audio channel in active cameo mode, press the **TALK** button. The **TALK** button LED will be lit and the camera channel in a cameo window will be the audio channel.

PIP Mode

You can display a Picture-in-Picture by pressing the **DISPLAY** button. You can change the location of the PIP by pressing the **Up** and **Down** arrow buttons and its size by pressing the **Left** and **Right** arrow buttons.

PTZ Mode

The DVR will control cameras with Pan, Tilt and Zoom capabilities. Press the **PTZ** button to enter the PTZ mode. You can control the camera using front panel control buttons or by setting up presets. To use the front panel buttons, press the **Left** and **Right** arrow buttons to pan left and right. Press the **Up** and **Down** arrow buttons to tilt the camera up and down. Press the **SEARCH** button to zoom in, and press the **PLAY/PAUSE** button to zoom out. You can use the **RW** and **FF** buttons to focus the image.

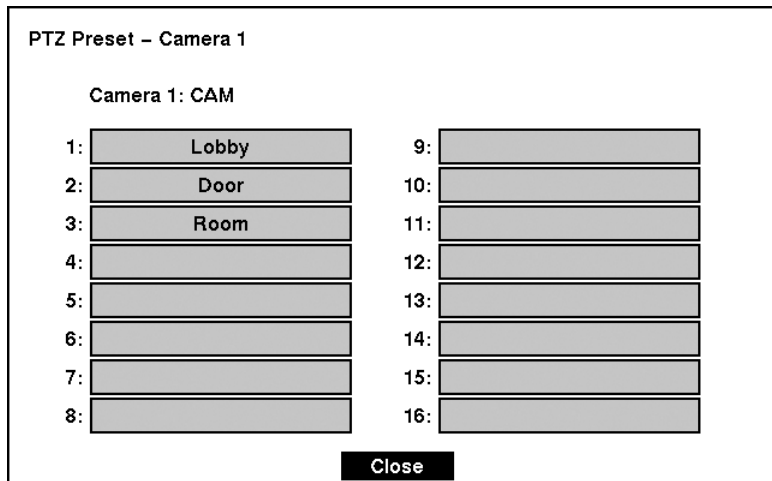

Figure 73 — PTZ Preset screen.

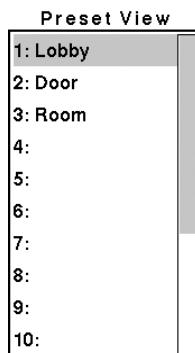

Figure 74 — Preset view screen.

You can save camera position settings as “presets” so that you can go directly to desired views. Once you have the camera at the desired settings, press the **STOP** button, and the PTZ Preset dialog box will appear. Select the number you want to assign to the preset and press the **↵** button. Use the virtual keyboard to enter the preset name. Press the **REC** button to load the PTZ preset and the Preset View dialog box will appear. Select the desired preset and press the **↵** button to load the preset.

Recording Video

Once you have installed the DVR following the instructions in *Chapter 2 — Installation*, it is ready to record. Unless you change the setup, the DVR will start recording when you press the **REC** button and will continue recording until the hard disk drive is full. The factory default is **Stop** when the hard disk drive is full. The DVR can be set to continue recording (**Overwrite**) once the hard disk drive is full. It does this by recording over the oldest video.

Although you will be able to record without changing the unit from its original factory settings, you will want to take advantages of the DVR's many tools. See *Chapter 3 — Configuration* for detailed descriptions of the recording mode options.

NOTE: The DVR only records video when the red REC on the display is lit. The DVR is NOT recording if only the red LED on the REC button is lit. When the DVR is set for Time-lapse or Event recording, the red LED on the REC button indicates the unit is ready to record. The red REC on the display will light and a red dot appears on the monitor when the clock reaches a scheduled recording time and the DVR starts recording video.

Recording Audio

If the DVR was set up to record audio, it will record audio when video is recording.

NOTE: Make certain you comply with all local and federal laws and regulations when recording audio.

Playing Recorded Video

Once video has been recorded, you can view it by pressing the **PLAY/PAUSE** button. When playing video for the first time, the DVR will display the most recent image. When playing video subsequent times, the DVR will start playing video from the last recalled image.

NOTE: Only the administrator level user can view the covert cameras. The covert cameras in the playback mode are determined by the current camera setting.

Pressing the **PLAY/PAUSE** button again will freeze the video on the screen.

RW (Rewind) Button

Pressing the **RW** button plays video backward at high speed. Pressing the button again toggles the playback speed from **◀◀**, **◀◀◀** and **◀◀◀◀**. The screen displays **◀◀**, **◀◀◀** and **◀◀◀◀** respectively.

Entering Fast Backward Playback mode from Live Monitoring mode can be password protected.

FF (Fast Forward) Button

Pressing the **FF** button plays video forward at high speed. Pressing the button again toggles the playback speed from **▶▶**, **▶▶▶▶** and **▶▶▶▶▶**. The screen displays **▶▶**, **▶▶▶▶** and **▶▶▶▶▶** respectively.

Entering Fast Playback mode from Live Monitoring mode can be password protected.

STOP Button

Pressing the **STOP** button during Playback mode returns the DVR to the Live Monitoring mode.

Camera Buttons (1 to 16)

Pressing a camera button will display that camera full screen.

DISPLAY Button

Pressing the **DISPLAY** button will cycle the display through the different screen layouts. The display modes are: full, 4x4, 3x3, and 2x2 (not all formats are available for the 9- and 4- channel DVRs).

Shuttle Ring

The Shuttle Ring only functions in the Playback mode. The Shuttle Ring is spring loaded and returns to the center position when released. Turning the ring clockwise plays video forward. Turning the ring counterclockwise plays video backward. Playback speed varies with the amount the ring is turned. The playback speeds are **◀x0.5**, **◀◀**, **◀◀◀**, **◀◀◀◀**, **▶x0.5**, **▶**, **▶▶**, **▶▶▶** and **▶▶▶▶**.

When you release the ring, it snaps back to the center position and the video pauses.

Jog Dial

The Jog Dial only functions when playback video has been paused. By turning the jog dial clockwise, you can play video forward image-by-image. By turning the jog dial counterclockwise, you play video backward image-by-image.

NOTE: When playing recorded video at maximum speed with very high image quality, playback of recorded audio may be interrupted occasionally.

NOTE: The user cannot change the system setup from a remote site during Playback mode.

Searching Video

Pressing the **SEARCH** button displays the Search Menu.



Figure 75 — Search Menu.

- Change Data Source — Changes the data source to be searched (see below for more details)
- Go to First — Displays the first image
- Go to Last — Displays the last image
- Date/Time Search... — Searches by date and time (see below for more details)
- Calendar Search... — Searches using a calendar (see below for more details)
- Event Search... — Selects video from the event log (see below for more details)

NOTE: The searching speed might decrease while all camera channels are in the pre-alarm recording mode.

Change Data Source

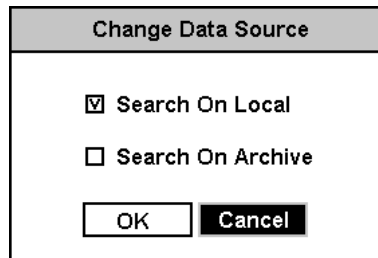

Figure 76 — Change Data Source screen.

You can select the data source to be searched from local storage (**Search On Local**) or archive storage (**Search On Archive**). To select the data source, highlight the data source to be searched and press the **↵** button.

Date/Time Search

The screen is titled "Date/Time Search". Below the title, it says "Enter Date/Time:". There are two input fields: the first contains "01-21-2002" and the second contains "07:04:55 AM". At the bottom, there are two buttons: "OK" and "Cancel".

Figure 77 — Date/Time Search screen.

Move the cursor over the date and press the button. You can use the Left and Right arrow buttons to highlight the year, month and day. Use the Up and Down arrow buttons to change to the date you want to search for video. Once you have set the date you want, press the button.

Move the cursor over the time and press the button. You can use the Left and Right arrow buttons to highlight the hour, minutes and seconds. Use the Up and Down arrow buttons to change to the time you want to search for video. Once you have entered the time you want, press the button.

Once you have set the date and time you want to search, highlight the button and press the button. The selected date and time will display. (If no video was recorded at the selected time, a blank screen will display.) The , , , Jog and Shuttle can now be used to review the surrounding video.

Calendar Search





The screen is titled "Calendar Search". It shows a calendar for the month of January 2002. The date "01-12-2002" is displayed at the top. The calendar grid has columns for days of the week (SUN, MON, TUE, WED, THU, FRI, SAT) and rows for dates. The date "12" is highlighted. Below the calendar is a timeline with markers at 0, 2, 4, 6, 8, 10, 12, 2, 4, 6, 8, 10. At the bottom, there are two buttons: "Go" and "Cancel".

Figure 78 — Calendar Search screen.

Days with recorded video display on the calendar with white numbers. You can highlight the days with recorded video by using the arrow buttons. Once you have highlighted a day, press the  button to select it.



A time bar will display at the bottom of the calendar. Hours in which video was recorded will be highlighted with blue. You can use the Up and Down arrow buttons to highlight the time bar. Once the time bar is highlighted, you can select the time by using the Left and Right arrow buttons.

NOTE: The time bar is in one-hour segments. If a segment is highlighted, it means that some video was recorded during that hour. However, it does NOT mean video was recorded for the entire hour.

Once you have set the date and time you want to search, highlight the GO button and press the  button. The selected date and time will display. The , , , Jog and Shuttle can now be used to review the surrounding video.

Event Search

| Event Log | | | |
|-----------|------------|-------|------------------------|
| No. | Type | Title | Date/Time |
| 4 | Alarm In 1 | | 12-04-2001 09:48:05 AM |
| 3 | Alarm In 1 | | 12-04-2001 09:47:55 AM |
| 2 | Alarm In 1 | | 12-04-2001 09:47:45 AM |
| 1 | Alarm In 1 | | 12-04-2001 09:47:35 AM |





4   Query...

Close

Figure 79 — Event Log screen.

The DVR maintains a log of each time the Alarm Input port is activated. The Event Search screen displays this list. Use the arrow buttons to highlight the event for which you would like to see video.

NOTE: Event Search does not work when the data source is set to "Search On Archive".

Pressing the  button will extract the event video and display the first image of the event. Pressing the  button will start playing the “event” video segment. Pressing  returns to live monitoring. Pressing  returns to the Event Log.

You can also narrow your event search by selecting Query... and setting up the new search condition.

Event Search

Search By

| | | | |
|------|---|------------|-------------|
| From | <input checked="" type="checkbox"/> First | 01-24-2002 | 01:56:57 AM |
| To | <input checked="" type="checkbox"/> Last | 01-24-2002 | 01:56:57 AM |

| Camera | | | | Event |
|--|--|--|--|--|
| <input checked="" type="checkbox"/> 1 | <input checked="" type="checkbox"/> 2 | <input checked="" type="checkbox"/> 3 | <input checked="" type="checkbox"/> 4 | <input checked="" type="checkbox"/> Alarm-In |
| <input checked="" type="checkbox"/> 5 | <input checked="" type="checkbox"/> 6 | <input checked="" type="checkbox"/> 7 | <input checked="" type="checkbox"/> 8 | <input checked="" type="checkbox"/> Motion |
| <input checked="" type="checkbox"/> 9 | <input checked="" type="checkbox"/> 10 | <input checked="" type="checkbox"/> 11 | <input checked="" type="checkbox"/> 12 | <input checked="" type="checkbox"/> Video Loss |
| <input checked="" type="checkbox"/> 13 | <input checked="" type="checkbox"/> 14 | <input checked="" type="checkbox"/> 15 | <input checked="" type="checkbox"/> 16 | |

Figure 80 — Event Search (by Camera) screen.

Event Search

Serach by

| | | | |
|------|---|------------|-------------|
| From | <input checked="" type="checkbox"/> First | 04-08-2002 | 11:28:37 PM |
| To | <input checked="" type="checkbox"/> Last | 04-08-2002 | 11:28:37 PM |

| | 1 | 2 | 3 | 4 | 5 | 6 | 7 | 8 | 9 | 10 | 11 | 12 | 13 | 14 | 15 | 16 |
|------------|-------------------------------------|-------------------------------------|-------------------------------------|-------------------------------------|-------------------------------------|-------------------------------------|-------------------------------------|-------------------------------------|-------------------------------------|-------------------------------------|-------------------------------------|-------------------------------------|-------------------------------------|-------------------------------------|-------------------------------------|-------------------------------------|
| Alarm In | <input checked="" type="checkbox"/> | <input checked="" type="checkbox"/> | <input checked="" type="checkbox"/> | <input checked="" type="checkbox"/> | <input checked="" type="checkbox"/> | <input checked="" type="checkbox"/> | <input checked="" type="checkbox"/> | <input checked="" type="checkbox"/> | <input checked="" type="checkbox"/> | <input checked="" type="checkbox"/> | <input checked="" type="checkbox"/> | <input checked="" type="checkbox"/> | <input checked="" type="checkbox"/> | <input checked="" type="checkbox"/> | <input checked="" type="checkbox"/> | <input checked="" type="checkbox"/> |
| Motion | <input checked="" type="checkbox"/> | <input checked="" type="checkbox"/> | <input checked="" type="checkbox"/> | <input checked="" type="checkbox"/> | <input checked="" type="checkbox"/> | <input checked="" type="checkbox"/> | <input checked="" type="checkbox"/> | <input checked="" type="checkbox"/> | <input checked="" type="checkbox"/> | <input checked="" type="checkbox"/> | <input checked="" type="checkbox"/> | <input checked="" type="checkbox"/> | <input checked="" type="checkbox"/> | <input checked="" type="checkbox"/> | <input checked="" type="checkbox"/> | <input checked="" type="checkbox"/> |
| Video Loss | <input checked="" type="checkbox"/> | <input checked="" type="checkbox"/> | <input checked="" type="checkbox"/> | <input checked="" type="checkbox"/> | <input checked="" type="checkbox"/> | <input checked="" type="checkbox"/> | <input checked="" type="checkbox"/> | <input checked="" type="checkbox"/> | <input checked="" type="checkbox"/> | <input checked="" type="checkbox"/> | <input checked="" type="checkbox"/> | <input checked="" type="checkbox"/> | <input checked="" type="checkbox"/> | <input checked="" type="checkbox"/> | <input checked="" type="checkbox"/> | <input checked="" type="checkbox"/> |

Figure 81 — Event Search (by Event) screen.

Highlight the box beside Search by and press the button to toggle between Camera and Event.

You can search video from the first to last recorded images, or you can set the start and stop times and dates.

When you select the **Search by Camera**, select the target cameras and event options. When you select the **Search by Event**, select event options for each device.

Once you set your desired search conditions, highlight **Search** and press the  button to display the search results in the **Event Log** screen. Selecting **Cancel** exits the screen without saving the changes.

Appendix A — USB Hard Disk Drive Preparation

Preparing the USB-IDE hard disk drive in Windows 2000

NOTE: Preparing a USB-IDE hard disk drive under Windows XP is almost identical to Windows 2000.

1. Connect the USB-IDE hard disk drive to your computer using the USB Cable.
2. Turn on your computer.
3. The USB device icon should display on the Taskbar.
4. If the USB-IDE hard disk drive is partitioned or has data, it will show up in *My Computer* as a hard disk drive icon. Check the file system by right clicking on the icon and checking under *Properties > General > File System*. If the file system is NOT FAT32 format, format the USB-IDE hard disk drive using the FAT32 format.
5. If the USB-IDE hard disk drive is not partitioned, go to *Administrative Tools* in *Control Panel* and launch *Computer Management*. Open *Disk Management* in *Storage* and right click an unallocated region of the USB-IDE hard disk drive. Then, click *Create Partition*.
6. In the *Create Partition wizard*, click *Next* then *Primary Partition*, and follow the instructions on the screen. Make sure that the FAT32 is selected for the file system.

NOTE: The partition size should be less than 32GB because of Microsoft limitations.

After formatting is complete, the USB-IDE hard disk drive will be added to *My Computer*.

7. Connect the USB-IDE hard disk drive to the DVR.

Preparing the USB-IDE hard disk drive in Windows 98

NOTE: Preparing a USB-IDE hard disk drive under Windows ME is almost identical to Windows 98.

1. Connect the USB-IDE hard disk drive to your computer using the USB Cable.
2. Turn on your computer. The *Add New Hardware wizard* window will appear.
3. Install the device driver for the USB backup device following the instructions provided with your USB hard disk drive.
4. If the USB-IDE hard disk drive is partitioned or contains data, it will show up in *My Computer* as a hard disk drive icon. Check the file system in *Properties > General > File System*. If the file system is NOT FAT32 format, format the USB-IDE hard disk drive with FAT32 format.
5. Run the FDISK utility by clicking *Start* then *RUN*. Type “fdisk” and click OK.
6. When the MS-DOS command prompt appears, type “Y” and hit the enter key.
7. In the FDISK Option menu, choose “5. Change current fixed disk drive.”

8. Choose the appropriate letter corresponding to the USB-IDE hard disk drive.
9. In the FDISK Option menu, choose "*1. Create DOS partition or Logical DOS Drive.*"
10. In the Create DOS Partition or Logical DOS Drive menu, choose "*1. Create Primary DOS Partition.*" And Type "Y" to use all available space and hit the enter key. Hit ESC to exit the screen after the USB-IDE hard disk drive partition is created.
11. Restart your computer and verify the newly created drive is in *My Computer*.
12. Right click the newly created hard disk drive icon and select "*Format*".
13. In the Format Screen, select "*Full*" as the "*Format type*" and click "*Start*".
14. After formatting is complete, connect the USB-IDE hard disk drive to the DVR.

Appendix B — Reviewing Backup (Clip) Images

Disconnect the external USB-IDE hard disk drive from the DVR, and connect it to your PC. You do not need to install any special software on your personal computer to review the video. The backup file contains the Player program. Double-clicking the target backup file starts the Player program.

NOTE: It is suggested that the computer used for the Player program has at least a 800MHz Pentium III. If your CPU is slower than this, backup files recorded at maximum speed with very high image quality will be played back slowly.



Figure 82 — Player screen.

Click the **Save** button to save the current image in a bitmap file format to the local hard disk drive or floppy disk.

Click the **Print** button to print the current image on the printer connected to your computer.

The **Backup File Information** window displays information regarding the backup file. **Location** displays the site description of the DVR where the backup was made. **Record** displays the time span of the video backup file. **Encryption** displays whether the backup file has been tampered with. **Normal** means the file has not been tampered with, **Wrong** means the system has detected tampering, and **no mark** means the user cancelled the encryption check.

The **Current Image Information** window displays information about the current image. **Camera Title** displays the camera name of the current image, and **Time** displays the date and time the image was recorded.

The **Playback Function Buttons** include fast backward, backward, play, pause, fast forward, go to the first image, go to the previous image, go to the next image, and go to the last image buttons.

The **Image Search Slide Bar** displays the current playback position. The user can move to another image clicking the mouse and dragging along the slide bar.

The **Brightness Revert Button** reloads to the original image.

The **Brightness Control Slide Bar** adjusts the brightness of the backup images by clicking the mouse and dragging along the slider bar. Minute brightness change can be made by using the arrow buttons located at each end of the bar.

Clicking the **OSD (On-Screen Display) Button** switches the OSD option. The OSD information includes camera location and date/time.

Clicking the **Mute** button mutes the recorded audio.

The **Monitoring Screen** displays the backed up images. Clicking the right mouse button on the images switches the screen size between 320x240 and 640x480.

Clicking the **Quit** button exits the Player program.

Appendix C — Troubleshooting

| Problem | Possible Solution |
|--|--|
| No Power | <ul style="list-style-type: none"> • Check power cord connections. • Confirm that there is power at the outlet. |
| No Live Video | <ul style="list-style-type: none"> • Check camera video cable and connections. • Check monitor video cable and connections. • Confirm that the camera has power. • Check camera lens settings. |
| Live Video Very Bright | If a cable is attached to the “Loop” connector, make certain it is connected to a properly terminated device. |
| REC LED is Lit but DVR is not recording | Unit will only record video based on the parameters such as schedule and events defined during configuration. Red REC LED indicates the DVR is ready to record. |
| DVR has stopped recording | If hard disk drive is full, you will either need to delete video or set the DVR to the Overwrite Mode. |
| DVR displays an error message stating that the last recorded image date and time is later than the current date and time setting of the DVR. | The DVR will automatically reset the time and date of the unit, according to the time and date of the last recorded image. If this is not the correct time and date, reset the time and date manually. If the correct time and date is earlier than the last recorded image, any video with a later time and date will be lost when resetting the correct time and date. |

Appendix D — Connector Pin Outs

I/O Connector Pin Outs

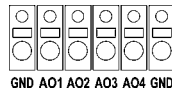
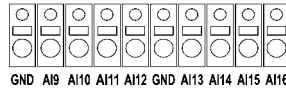
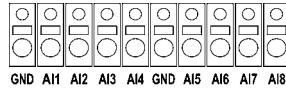

| | |
|--------------|-------------------------------|
| AI (1 to 16) | Alarm Inputs 1 to 16 |
| GND | Chassis Ground (4 connectors) |
| AO (1 to 4) | Alarm Outputs 1 to 4 |
| ARI | Alarm Reset In |

RS485 Connector Pin Outs

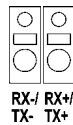

| Master Unit | Slave Unit |
|------------------------|------------|
| RX-/TX- → To → TX-/RX- | |
| RX+/TX+ → To → TX+/RX+ | |

Observation Camera Connector Pin Outs

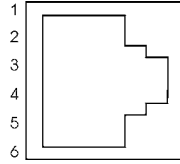

| | |
|-------|-----------------------|
| F n 1 | Alarm Input |
| F n 2 | +15VDC Output |
| F n 3 | Intercom Audio Output |
| F n 4 | Video Input |
| F n 5 | Intercom Audio Input |
| F n 6 | Ground |

Appendix E — Map of Screens

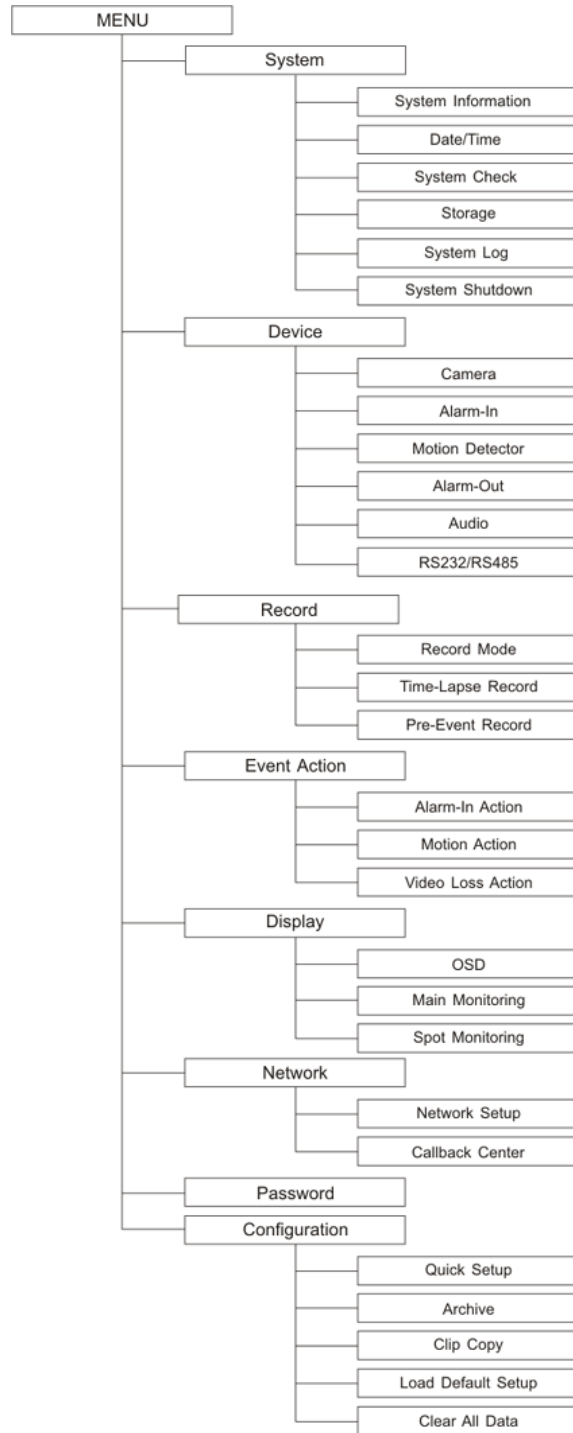

Appendix F — Specifications

| VIDEO | |
|--|---|
| Signal Format | NTSC or PAL (selector switch) |
| Video Input | Composite: 4, 9 or 16 looping inputs, 1 Vp-p, auto-terminating, 75 Ohms |
| Monitor Output: | Composite: One, 1 Vp-p, 75 Ohms SVHS: One SPOT: 1 BNC |
| Video Resolution | 720x480 (NTSC), 720x576 (PAL) |
| Playback/Recording Speed (images per second) | 60ips (NTSC), 50ips (PAL) |

| INPUTS/OUTPUTS | |
|----------------------|---|
| Alarm Input | 4, 9 or 16 TTL, NC/NO programmable, 4.3V threshold (selectable from terminal inputs or camera alarm inputs) |
| Alarm Output | 4 TTL open collector, 5mA@12V, 30mA@5V |
| Alarm Reset Input | 1 TTL, 4.3V threshold |
| Network Connectivity | 10/100 Mbps Ethernet RS-232C for external modem |
| Audio Input | RCA Input: One “line in” or “mic” programmable Camera Audio Inputs: 16 “line in” programmable with RCA input |
| Audio Output | One, “line” |
| Internal Microphone | One |
| Internal Speaker | One |

Specifications are subject to change without notice.

| CONNECTORS | |
|---------------------|--|
| Video Input | Composite: 4, 9 or 16 BNC / 4, 9 or 16 RJ-11 |
| Video Loop | Composite: 4, 9 or 16 BNC |
| Monitor Output | Composite: 1 BNC SVHS: 1 Y/C SPOT: 1 BNC |
| Audio In | RCA connector / RJ-11 |
| Audio Out | RCA connector / RJ-11 |
| Alarms | Terminal block |
| Ethernet Port | RJ-45 |
| Modem Port | RJ-11 |
| RS232C Serial Port | DB9 (P) |
| RS485 Serial Port | Two-connector terminal block |
| UltraWide SCSI Port | High density female 68 pin connector |
| USB Port | One |

| STORAGE | |
|-----------------|---|
| Primary Storage | EIDE hard disk drive (up to 2) |
| Backup Storage | UltraWide SCSI hard disk drive (RAID) Built-in CD-RW drive USB hard disk drive or CD-RW drive |

| GENERAL | |
|---------------------------------|--|
| Dimensions (W x H x D) | 16.9" x 3.5" x 14.0" (430mm x 88mm x 357mm) |
| Unit Weight | 18.4 lbs. (8.35kg) |
| Shipping Weight | 26.2 lbs. (11.90kg) |
| Shipping Dimensions (W x H x D) | 21.3" x 10.2" x 19.7" (540mm x 260mm x 500mm) |
| Operating Temperature | 41°F to 104°F (5°C to 40°C) |
| Operating Humidity | 0% to 90% |
| Power | 100 to 240 VAC, 1/2 A, 60/50Hz |
| Input Voltage | 24VDC, 6.3A |
| Power Consumption | Max. 150W including observation camera power 64W |

| APPROVAL | |
|-----------------|--------------------------------|
| FCC | FCC PART 15 Subpart B, Class A |

Specifications are subject to change without notice.